



***300 stimulating ideas for
IB Physics Practical
Investigations & EE's***

Source: Dr, Richard Walding, Griffith University, Queensland, Australia.

Here are 300 suggestions to get you started on your Physics EEI. For an example of an 'Open' EEI task sheet, [click here](#).

NOTE about projectiles & weapons:



This potato gun is most likely a "firearm".
See the note to the right for a caution.

Several suggested 'projectile' EEIs below feature devices that may be considered as "weapons" or "firearms" under Queensland Weapons Act (1990). Before you get too far into making such a device you should consult the [categories of weapons](#) website provided by the Queensland Police Service or their [weapons licensing main page](#) and links. Even if your device is not a weapon under the Act your teacher may consider it too dangerous for a school activity. Be warned before you get too carried away.

The potato cannon (or "spud gun") shown on the left is likely to be a Category B weapon as it is a "Muzzle Loading Firearm". It is classified as a "firearm" as it is a "weapon that on being aimed at a target can cause death or injury". "Injury" is defined as "bodily harm" which is further defined as causing a bruise. If it is a weapon then you may need a firearms license to operate it. A small "spud" (potato) gun may not be a firearm. You should check and not rely on any of the comments above. This category is likely to be clarified in the new Act.

Catapults, trebuchets, and bows & arrows - are not considered weapons (even though they can be lethal). If they are used for a "behavioural offence" to harm someone (eg attack them) they then become a "weapon" under the Act and the rules about bodily harm apply. This is similar situation to a baseball bat, a kitchen knife and so on which are also not weapons unless used for a behavioural offence. Catapults, trebuchets & bows & arrows fall in to this area. If a projectile from your trebuchet goes off course and hits someone on the head 100 m away and causes bodily harm then you or the school may be a big legal and medical problem; but it would appear that the police would not consider it an offence under the Weapons Act as it is not a "weapon" and a "behavioural offence" was not intended despite bodily harm being done. Someone may get sued, lose their job, or whatever, but not for a breach of the Weapons Act. Further, **none of the above should be taken as a legal advice** as it is merely my understanding based on a conversation with an officer from the Queensland Weapons Licensing Branch.

RISK ASSESSMENT:

Teachers in non-government schools may find the Queensland Department of Education and Training's [Curriculum Activity Risk Management Guidelines](#) (CARA) useful.

- **Making and testing a trebuchet**

A trebuchet is a siege engine that was employed in the Middle Ages either to smash masonry walls or to throw projectiles over them. A trebuchet works by using the mechanical principle of leverage to propel a stone or other projectile much farther and more accurately than a catapult, which swings off of the ground. The sling and the arm swing up to the vertical position, where usually assisted by a hook, one end of the sling releases, propelling the projectile towards the target with great force. You could investigate the variables to optimise a catapult/trebuchet (see photo below) - measure range vs. GPE of weight, length and position of arms; why do these affect range? **Please note:** it is all very well to make spectacular and intricate trebuchets (eg carved and polished oak or pouring your own lead counterweight complete with ancient inscriptions of battles won), and it is all very well to do heaps of testing (battling each others castles on the footy oval); but unless you meet the requirements of the criteria in analysis, discussion, evaluation etc there is little hope for a good EEI grade. **Be warned!** Your teacher will also be concerned about safety (see "[weapons](#)" note above). You will have to get parental supervision if you are using power tools or testing it at home. Secondly your teacher will no doubt place a limit on the size of the throwing arm/counterweight or the projectile. Some teachers have wisely said: the trebuchet must be small enough to fit on a school desk; the projectile should be soft, eg a softball; or the projectile should have a mass no more than a golf ball. Teachers report some lethal trebuchets used to launched huge projectiles in the back yards of suburbia. However, there have been students who made ballista out of paddle-pop sticks and received an "A".

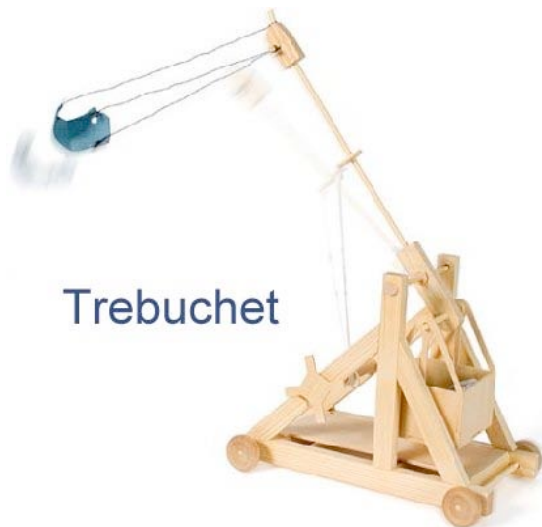

Home made trebuchet - okay for an EEI



Not okay!

Below are some photos of the setup Luke Hoffman from Carmel College, Thornlands, used for his trebuchet EEI in Year 12.

Extra photos can be downloaded ([click here](#)).

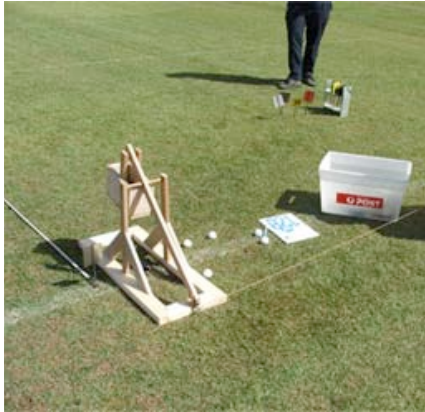

Luke Hoffman sets up his trebuchet on the oval at Carmel College.



The counterweights

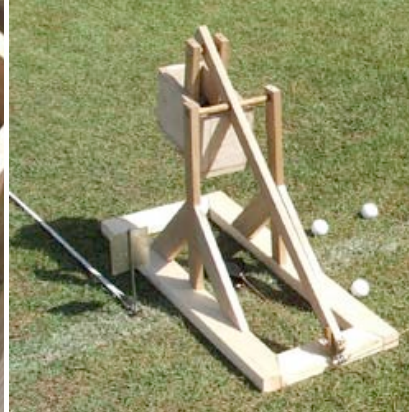

Close-up of the trebuchet

- **Fun with a toy helicopter**

If you want to play with a remote controlled helicopter and do a Physics EEI at the same time - here's an idea suggested by our colleague Michael Liebl, Physics teacher at Mount Benedictine High School, Elkhorn, Nebraska, USA. A helicopter flies by means of the thrust that is created by the rotation of the blades of a main rotor that is mounted on a shaft above the fuselage of the aircraft (see below). As the blades rotate, an airflow is created over them, resulting in lift. This raises the helicopter. Newton's third law requires that the air in turn exert an equal force upward on the rotor. For a helicopter to hover, the force exerted by the rotor blade on the air must be equal to the weight of the helicopter. With a few simple assumptions and basic laws of physics, it can be shown that the relationship between rotational frequency of the rotor blade (f) and the mass (m) of the helicopter is: $f^2 = mg / (8\pi^3 \rho \lambda^2 R^4)$ where ρ is the air density, R is the rotor radius, and λ is a constant. A great EEI would be to buy a remote controlled helicopter off ebay for about \$25, tape it to the pan of an electronic balance and vary the rotational speed (how to measure? You decide!). You're not trying to prove the formula but look for relationships between various quantities such as mass, frequency, radius, blade angle and so on. What fun! Here's an article from [The Physics Teacher](#) that gives a bit of the theory.



Tape the toy helicopter to the balance

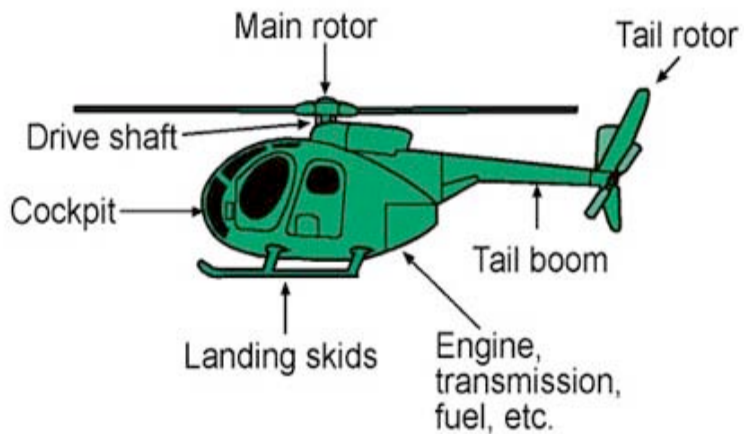

Parts of a helicopter

Singing wine glass

You can make a wine glass sing a pure tone by rubbing your degreased and wetted finger around the rim. Vibrations are set up in the wall of the glass and resonance occurs in the air column. When you increase the volume of water inside the glass the frequency of the sound changes (increases/decreases? - you find out). A lot of it is counter-intuitive! But is the pitch proportional to the circumference, the diameter of the glass or the amount of liquid in the glass? Physics books give wayward opinions and you could finally work out who is right and what factors are involved. Capture the sound on a CRO and work out the frequency. Four variations you could try are shown below. The last one has a solid column in the glass so there is less water but the same water level. Or you could compare liquids of different density or viscosity; or non-polar (hexane) with polar (ethanol). Don't try to do too many variables or you'll run out of time.

Here's a stimulus for developing a great EEI based on the Singing Wine Glass. My thanks to Physics teacher Steven Anastasi from The Cathedral College, Rockhampton, Queensland: "One would expect that a singing wine glass behaves like a closed pipe, but a few simple tests challenge this fact. For one thing, filling the glass with water would imply that the note goes up, not down. Does it? That said, the length of a wine glass is very short, so the frequency might be so high you just don't hear that note. Perhaps these days there is software available that can 'hear' well above the range of human hearing, and this would be worth investigating by doing a theoretical analysis of the frequencies expected, then searching for them with technology. Yet there remains the question of what variables influence the frequency of the singing wine glass, and testing the frequency heard is just one aspect, and a little bit simple for a thorough going physicist. Is it the thickness of the glass? The volume of water, the height of water? The percentage of water from the top/bottom of the glass? Is it a coupling of the water to the glass? Is there a temperature effect? Is it predictable. Indeed, the holy grail of singing wine glasses is to arrive at a formula that predicts the frequency that might be heard, for well justified reasons. Your object ought to be to arrive at an answer. This might be discoverable using your fancy calculator, but that is maths (barely) not physics. In the end you should be able to provide reasons for its behaviour, based on your personal observations, and verifiable by prediction based on equations or by trend." If you think that the pitch is lowered when you add water to the glass you are right (diagram 1 below); but if you say this is because the added liquid is forced to participate in the vibration of the glass wall, then wouldn't you get a similar result for diagram 2 below? Well you don't - and therein lies the beauty of this for an EEI.



Kayla makes the wineglass sing - at Moreton Bay College



Some possible variables.

- **Guitar Strings and Mersenne's Law**

You should be well aware that as you tighten a guitar string its pitch (sound frequency) increases; and the thick strings wound with copper produce a lower frequency than the lightweight steel or nylon ones. This is the basis of Mersenne's Law: the fundamental frequency of a vibrating string is proportional to the square root of the tension and inversely proportional both to the length and the square root of the mass per unit length. You could investigate this for yourself but the Law is only the starting point; it's no good just proving the law by using a recipe-style experiment - that's hardly the recipe for a good EEI. You'll have to extend the experiment: does the law have limitations, does it work at all temperatures; how much stretching do the strings undergo; do they obey Hooke's Law? Some more suggested research questions have been made by Physics teacher Stephen Pinel to whom I am most grateful:

- As a string is tightened, does the spread and amplitude of harmonics change?
- If the string length changes (same tension) does the spread and amplitude of harmonics change?
- As a string cools/heats, does the spread & amplitude of harmonics change?
- If two strings create a particular interval (like C-G), do they stay in tune if their temperature changes?



- **Comparison of Musical Instruments - effect of temperature**

Here's a stimulus for developing a great EEI in the context of *The Physics of Music*. My thanks to Physics teacher Steven Anastasi from The Cathedral College, Rockhampton, Queensland: "Musicians usually tune their instruments at the last moment. Might there be a good reason for this? Compare and contrast the physics of a woodwind instrument (e.g. recorder) to that of a stringed instrument (e.g. guitar). What differences in pitch might you expect of each instrument in changed temperature conditions? This might be considered from several perspectives – the air temperature, or the temperature of the instrument, preferably both. You know from theory that the frequency of the woodwind instrument is related to the speed of sound, and from thermodynamics that the speed of sound in air is different when it is colder. How would this affect the note, and can you describe this with equations? Similarly, does a guitar string 'speed up' or 'slow down' when it is cold? Does the frequency also depend on the speed of sound in air? Would a woodwind player and a guitarist have the same tuning issues if they gave a concert in a freezer? How could a woodwind player tune his/her instrument? Your task is to consider this from a theoretical perspective, then test it in an experimental setting. Variables that might be considered include whether end correction of the woodwind instrument changes against the controlled variable. Does it matter which note you are testing? Is there a connection between end correction and the note? Could you 'correct' the instrument by adding or removing the tip of the wind instrument?"

- **Optimise a water rocket**

A water rocket is a type of model rocket using water as its reaction mass. The pressure vessel - the engine of the rocket - is usually a used plastic soft drink bottle. The water is forced out by a pressurized gas, typically compressed air. As the water is ejected the rocket's mass becomes less so less force is needed to maintain acceleration; but as the gas expands its pressure becomes less and can provide less force. How do these competing factors affect the motion of the rocket. You could look at height or time of flight vs initial mass of water, pressure, nozzle area, mass of rocket. Explain the physics to justify your hypothesis or will you do it by trial-and-error? A detailed examination of the maths behind water rockets has been provided by Dr Peter Nielsen from Department of Civil Engineering at the University of Queensland. [Click here](#) to download. He has also provided a [rocket simulator spreadsheet](#) to examine the factors theoretically. You may also be interested to know that the Asia-Pacific Regional Space Agency Forum (APRSAF) hosts an annual [Water Rocket event](#) in which one student between 12 and 16 years of age, and an accompanying teacher is selected from each Australian state and territory to participate in a competition. The criteria for the rocket is to hit a 4m diameter target at a range of 60m.



- **Factors affecting the trajectory of a solid fuel rocket**

This is a popular one if you are able to get hold of rocket "motors". At Home Hill SHS, Queensland, Yr 11 Physics students undertake EELs based around rocket flight with their Physics teacher (and resident *Rocketman*) Mr Robert Scalia. Here's a part of the introduction student Patrick Puddlefoot from Home Hill SHS, Queensland wrote in his EEL: *A rocket has four basic forces acting on it when in flight. These forces are lift, weight, thrust and drag. The lift force acting on a rocket in flight is usually pretty small. The other three forces, however, all directly impact the maximum height the rocket can reach. Weight is a function of how each component of the rocket is designed. The lighter the rocket is, the higher it will be able to go all else being equal. Thrust is generated by the rocket's motor. The more thrust the motor produces, the higher it will go. However, neither of these forces is heavily dependent on the nose shape. The force that has the most effect and does vary significantly with the shape of the nose is drag.* Patrick decided to investigate nose shape (cylindrical, elliptical and pointed) as a factor in a rocket's performance. You can read his [abstract here](#) along with a couple of his data tables and a comment on the method. The rockets and altimeters were purchased directly by Robert Scalia from [Apogee Components](#) in the USA. He said there were no real problems apart from some faulty launch controllers "which they replaced promptly". Rockets are quite inexpensive and the altimeters cost approximately \$90 each (but are reusable). "Estes" C6-5 engines were purchased from the local *Toyworld* store for \$14.99 for a pack of 3. [Click here to see the Toyworld catalogue page](#). Robert said that he was looking at less powerful engines in 2011: "The C6-5s are spectacular but you need a large area for testing and a small amount of wind as

it's likely they will go missing". Note: The letter "C" represents the total impulse in newton seconds: A = 2.5, B = 5, C = 10, and D = 20. The first number after the letter represents the number of seconds of engine thrust. The second number represents the number of seconds of delay between the end of engine thrust and the reverse (recovery system deployment or second stage ignition) charge. Thus a type C6-5 delivers 10 newton seconds of thrust in a six second burn, followed by a five second delay. Other common types available are: A8-3, B4-4, B6-4, B6-6, C6-3, C6-5, C6-7 and (gulp!) the D12-5. I'm guessing Home Hill SHS will be going for the B6-4 this year.



Patrick's nosecones. Extra mass was added to the payload of the pointed and elliptical cones so that each rocket had the same mass.

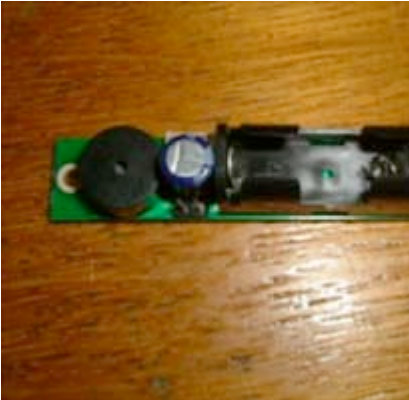

The altimeter: once the rocket was back on ground the altimeter will be heard to make an irregular beeping sound. These beeps tell you how high (apogee) the rocket reached; e.g. five beeps followed by two beeps followed by two beeps means that that rocket reached an apogee of 522 ft.



The altimeter's data can be downloaded via a USB connection and analysed for altitude, acceleration and velocity of rocket flight. [More photos from Patrick's EEI can be seen here.](#)

The photos below were taken by Amanda and supplied by Physics teacher from Home Hill SHS - Mr Robert Scalia.



Megan Lipsys and Paul Barker measure



Detonating the rocket engine electrically



The elliptical-nosed rocket reached an

the characteristics of different nose cones using a TI *Ranger*, and a TI CBL2 data collector.

on the oval at Home Hill SHS

apogee of 199.24 m

Energy output of a solar panel

Photovoltaics (PV) is a method of generating electrical power by converting solar radiation into direct current electricity using semiconductors that exhibit the photovoltaic effect. Photovoltaic power generation employs solar panels comprising a number of cells containing a photovoltaic material. The Australian Government provides incentives for the use of PVs for both domestic and industrial use (you can save money, and save the environment). Solar photovoltaics generates electricity in more than 100 countries and, while yet comprising a tiny fraction of the 4800 GW total global power-generating capacity from all sources, is the fastest growing power-generation technology in the world. Between 2004 and 2009, grid-connected PV capacity increased at an annual average rate of 60 percent, to some 21 GW. A good EEI would be to measure current as a function of the angle of incidence of sunlight (all within a short period of time eg 30 minutes); measure current when collector is perpendicular to rays during the day (how should that go?). But maybe you'll need to consider more than current; perhaps the power output is more important. If so, you could put a load on the circuit (resistor) and measure V and I. In the method shown below, Moreton Bay College students are measuring the effect of angle on the flow rate (hence power output) of a electrical water pump. This was Year 10.



- **Energy output of a solar panel II**

You could also investigate the effect of shade on the output of a panel. In this photo, students are using layers (1, 2, 3 etc) of shade cloth. It would also be interesting to see the effect of light of different wavelength to see if the solar cells are sensitive to all wavelengths. You could use coloured cellophane - but then that reduces intensity and not all coloured cellophane has the same percentage transmission. What to do?

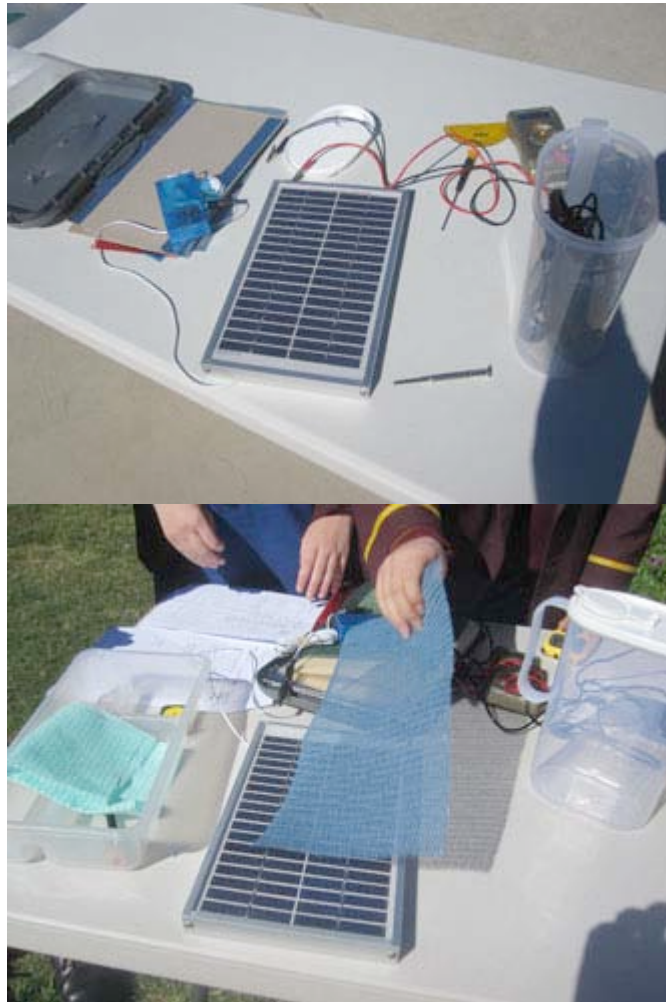

- **The Effect of Dust on Solar Cell Performance**

Photovoltaic cells have low conversion efficiencies (typically up to 20%), the accumulation of sand and dust particles on their surface further reduces their output efficiency. This limitation makes photovoltaic cells an unreliable source of power for unattended or remote devices, such as solar-powered traffic signs or NASA's Mars Rover. For large-scale solar plants to maintain their maximum efficiency, the photovoltaic cells must be kept clean, which can be a challenging task in dusty environments. One good EEI would be to investigate the effect of dust on the solar panel. This is a harder EEI than the two above. It involves setting up a solar panel a short distance from an incandescent bulb (eg 15 cm) and adding controlled amounts of "dust" (eg bentonite clay powder, fine sand, icing sugar) to the face of the panel (spread

evenly). It is a good idea to adjust the panel so it is working at maximum power. Do this by setting up the circuit on the left below, using either a variable resistor or fixed resistors that can be varied from 0 ohm to 300 ohm. Plot a graph (next figure) to see the maximum power point. Then add the bentonite (0.1g, 0.2 g and so on) and record the V and I (and the product P). Efficiency = $P_{\text{dust}}/P_{\text{no dust}} \times 100\%$. A good article is in *Physics Education*, V45, September 2010, page 456.

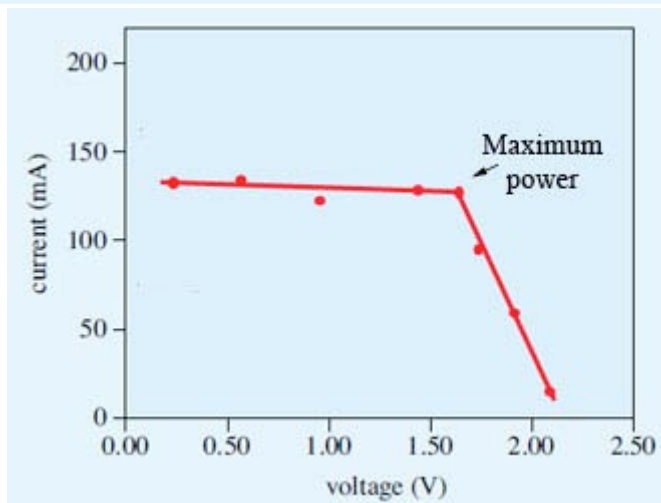
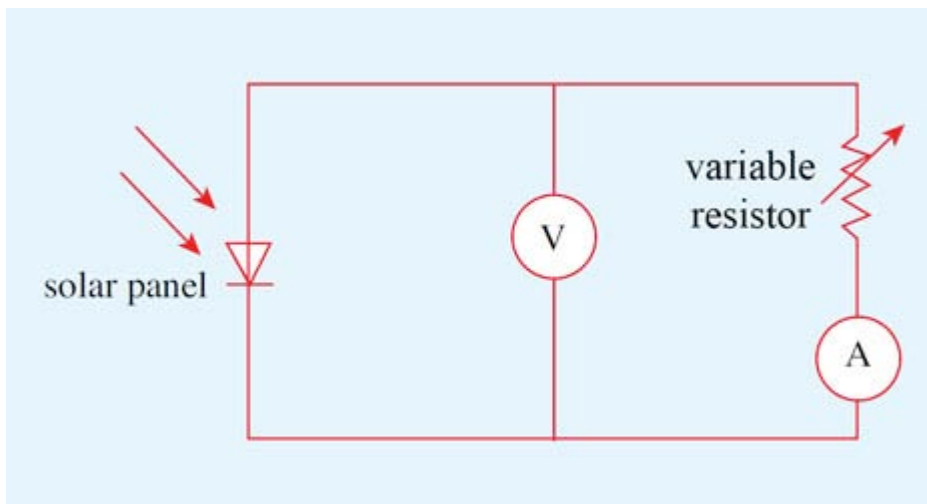

- **Water discharge from a pinhole in a water bottle**

You've probably seen a demonstration of water coming out of holes in the side of a water bottle and a discussion about height and range of the water. The water speed v at the hole depends on the height H of the free liquid surface above the pin-hole, according to Torricelli's law $v^2 = 2gH$ where g represents the acceleration due to the force of the Earth's gravity. This result was obtained by Galileo's assistant E Torricelli in 1636. It is normally obtained nowadays through Bernoulli's theorem $p + \frac{1}{2}\rho v^2 + \rho gy = C$ introduced by Daniel Bernoulli in his book on hydrodynamics of 1738, which appeared a century ago ($C =$ a constant, $y =$ height). The variables are obvious but the level of the ruler below the bottle must be controlled (there's a hint for another independent variable). If you are really keen you could do the two bottle experiment as shown below. There is a good paper on this experiment by de Oliveria et al from Brazil in [Physics Education V35\(2\) March 2000, 110-120](#) (click to download).

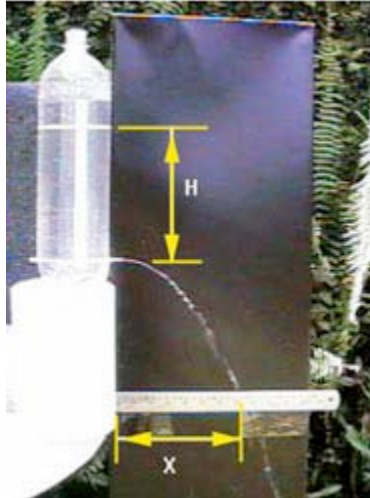

Single bottle



Two bottle experiment



In the lab at Moreton Bay College.

- **Water discharge from a leaky bucket**

Whether its at hole in a dam wall or a leaky urn in the tuckshop - leaks are annoying. But the rate of flow of water from a reservoir is obviously dependent on the height of water above the hole (the 'head') and the size of the opening. Engineers model fluid flow through an orifice so they can design the optimum combination when the flow is desirable, and the design safety devices for coping with accidents when the flow is not wanted. A great EEI can be done on this topic. I just saw a great one by Year 12 student Steven Ettema from Brisbane Bayside State College using a bucket of water, a Pasco force meter and a computer to collect the data. His teacher Mr Ben Robson was very impressed. Steven's dependent variable was the change in weight (F_w) of the water with time, and his manipulated (independent) variable was the size of the hole in the bucket (see diagram below). His development and justification of the hypothesis was breathtaking. To tantalise you I can report that it took 14.3 seconds to drain 3 L of water through a 2 mm orifice, and 2.8 s for a 6.5 mm hole. But it is not the total time that is important - it is the rate of emptying, and the shape of the rate/time graph, and the analysis and discussion afterwards.



- **Water discharge from a water rocket**

Steven's idea mentioned above can also be used to measure the change in flow rate with time from a water rocket (plastic water bottle partly filled with water and pressurised). When the stopper is removed the water jets out under gas pressure. However, as the air in the headspace expands, the pressure decreases and you would think the rate of flow gets less. All you need to do is prepare a pressurised

water rocket in a water bottle, suspend the water rocket from the ceiling using a force meter to measure the weight, and then remove the stopper from the mouth. As the water comes out the force meter will give you a reading of the weight (gets less - but maybe not regularly). You could then consider changing the starting pressure or the volume of water or whatever you like. My thanks to Steven Ettema at Brisbane Bayside State College and his teacher Ben Robson for suggesting this.



Water flow I - Poiseuille's Law

The study of the flow of real fluids through tubes is of considerable interest in physics and chemistry as well as in biomedical science (flow of blood in arteries) and in engineering. Engineers have to keep water moving in pipes to supply cities with drinking water, and to take waste water away. They know that the speed of the water depends on the viscosity, the diameter of the pipe, the length of the pipe and the pressure difference. Poiseuille's Law quantifies these quantities in the formula: $Q = \frac{\pi R^4 \Delta P}{8\eta L}$. You can look this up to find out what the symbols mean. A first year university experiment is shown in the diagram below but you could do it with a Buchner flask in place of RF (below) and a plastic water bottle, stoppers and glass tubing. You hook up a vacuum pump to reduce the pressure in flask RF and when the valve "A" is opened water flows from jar CF through the pipe "T" into the flask RF. By measuring the volume of water collected in a given time for a controlled pressure and tube diameter and thickness you can look at relationships. Then vary the length of the pipe, or its thickness, or the pressure, or the viscosity and so on. What a fabulous experiment for an EEI. A paper about this experiment is available from the [European Journal of Physics V27 \(2006\) 1083-1089](http://www.eurjphys.org/issue.php?id=V27(2006)1083-1089). Click to download. If you do it as an EEI please send me a photo for this webpage.

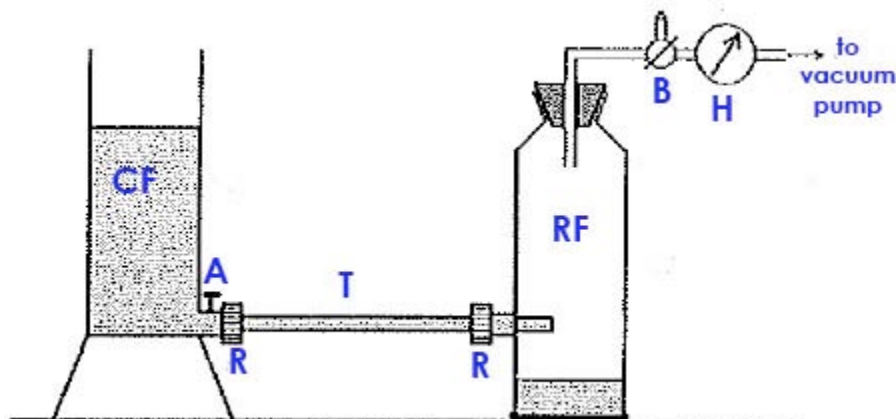

- **Water flow II - Poiseuille's Law**

Another neat way of exploring the factors affecting flow rate in liquids is shown in the diagram below. It could be used in university physics. The motion sensor measures the changing height of the water column by using an ultrasound beam. These are commonly available in high school laboratories these days (Vernier, DataLogger Pro etc). Again, by changing the thickness of the tube, or length, or viscosity you can measure the rate of change of height (the height of water is related to pressure ($P = F/A = mg/A = \rho gh$)). For high school, you could also keep pressure constant by having a small hose from the lab tap going into the top of the column (and doing away with the motion sensor). You could do it with a plastic water bottle, a stopper or two and some glass tubing. What a great EEI! A paper about this experiment is available from the [European Journal of Physics V29 \(2008\) 489-495](#). Click to download. If you do it as an EEI be sure to send me a photo for this page.

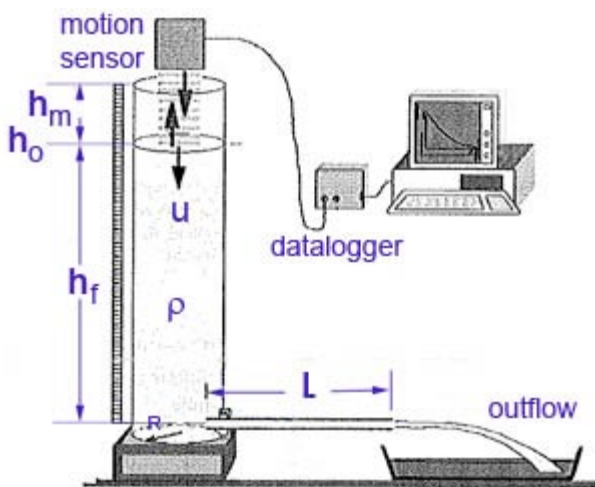

- **Water flow III - Saxon Bowls**

The earliest means of measuring time was by the observation of celestial bodies (Sun, Moon, stars). However, not far behind were water clocks. One of the oldest was found in the tomb of the Egyptian pharaoh Amenhotep I, buried around 1500 BCE. Later named *clepsydras* ("water thieves") by the Greeks, who began using them about 325 BCE, these were stone vessels with sloping sides that allowed water to drip at a nearly constant rate from a small hole near the bottom. In a variation, the Saxons (ancestors of modern-day English, Germans and Dutch) would place a small bowl with a hole in its bottom in a larger container of water. It would slowly sink as water rushed in through the hole and finally submerge when full. The Saxons used the time it took the bowl to submerge to limit orations (speeches). There is a story that other service providers used such bowls to allocate their customer's time. These were still in use in North Africa in the 20th century. It is highly likely that there is a relationship between the diameter of the hole and the time until submergence (and it won't be linear so plenty of data points). However, as water enters the hole and the bowl fills you would think it would get harder and harder for more water to enter. Maybe or maybe not. Also, it would seem that as the cup sunk the hole would be further from the surface and thus experience greater pressure. I've seen these cups made from the plastic (PVC) caps they use for plumbing (see below). Buy a lot, drill holes of varying diameter and Bob's your uncle. You may need one drop of detergent (why?). You could even use an old jam tin or something like that (which may give a longer sink time). There are lots of errors to talk about.



40 mm PVC cap from Bunnings
\$1.98 each



Drill hole



Water comes in



Starting to sink



Almost gone



Gone

Refractive Index and Temperature

Since the density of a liquid usually decreases with temperature, it is not surprising that the speed of light in a liquid will normally increase as the temperature increases. Thus, the index of refraction normally decreases as the temperature increases for a liquid. For many organic liquids the index of refraction decreases by approximately 0.0005 for every 1°C increase in temperature. However, for water the variation is only about -0.0001/°C. A good EEI would be to examine the relationship between RI and temperature for water and perhaps other liquids. Does it vary regularly with temperature; is it related to the coefficient of volume expansion; do solutions of ionic or molecular solutes have any effect and, if so, why? The possibilities are endless. You need to get hold of a triangular tank which can be filled with the liquid and a laser beam shone through it. Lay it flat on a hotplate and away you go. You could easily make one from microscope slides and epoxy glue or silicone. Before you get too far consider whether you can measure such small variations in refraction. Also, give some thought to which of the two set-ups below would be easier to analyse.

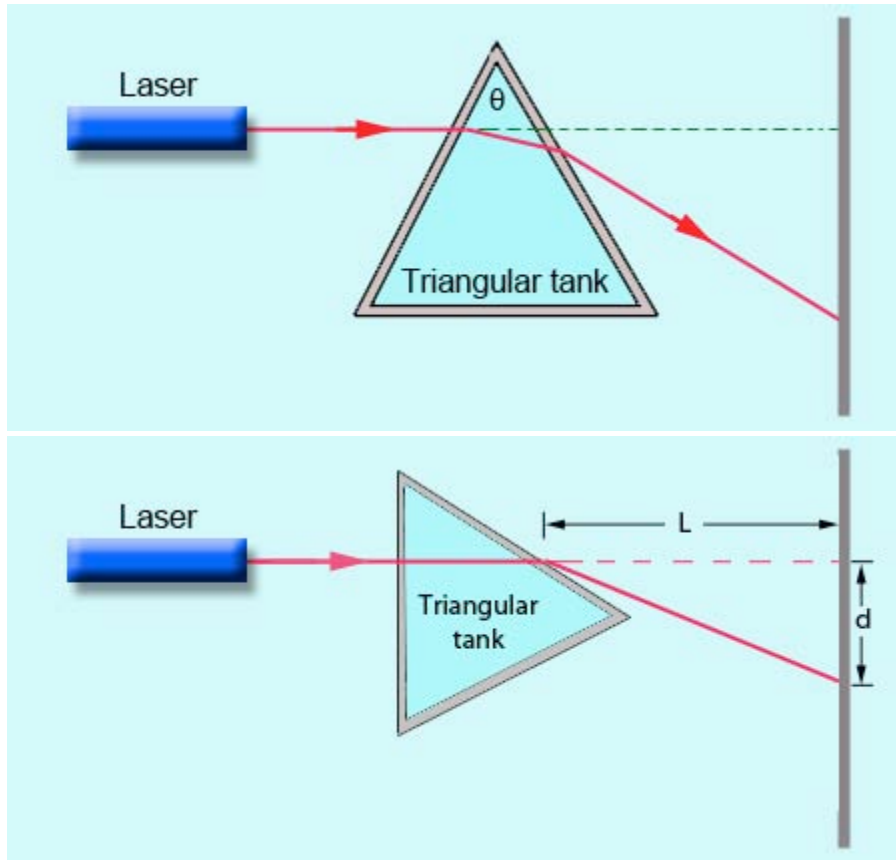

- **Refractive Index of a liquid: another method**

Another method of measuring the refractive index of a liquid is shown below. A laser beam is shone on to a piece of flat glass (eg microscope slide) placed horizontally in a dish. The beam reflects on to a wall and all necessary distance measurements are taken. While the laser is held rigidly in the same position, water (or any liquid under test) is added to the dish to a measured height above the surface of the glass and two reflections are seen on the wall: one from the surface of the water and one from the interface between the water and the glass slide. Again all necessary measurements are taken. Using some fairly straightforward geometry the refractive index of the water can be calculated. How to make this an EEI? You could consider making a series of measurements at different water depths and plotting them to see if RI is constant over the range of depths. The accuracy of the smaller depths can be commented upon. You could always perform this on a hotplate as in the above experiment and look at RI vs temperature, or you could think of something more imaginative. My thanks to Prof. Shyam Singh, Department of Physics, University of Namibia, Windhoek, Namibia for this suggestion (*Physics Education*, March 2002, p152).

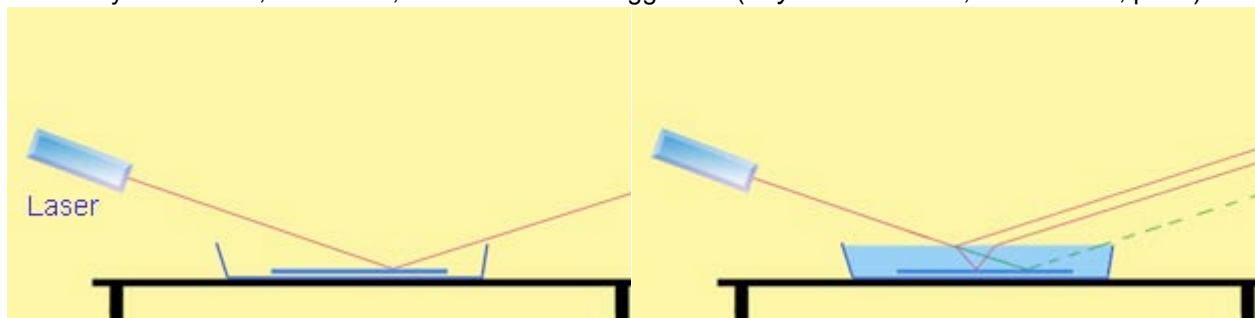

Firstly, without water. Clamp the laser in a stand and make sure the glass is dead level.

Then add some water and you should get two reflections. The green dotted line is the original.

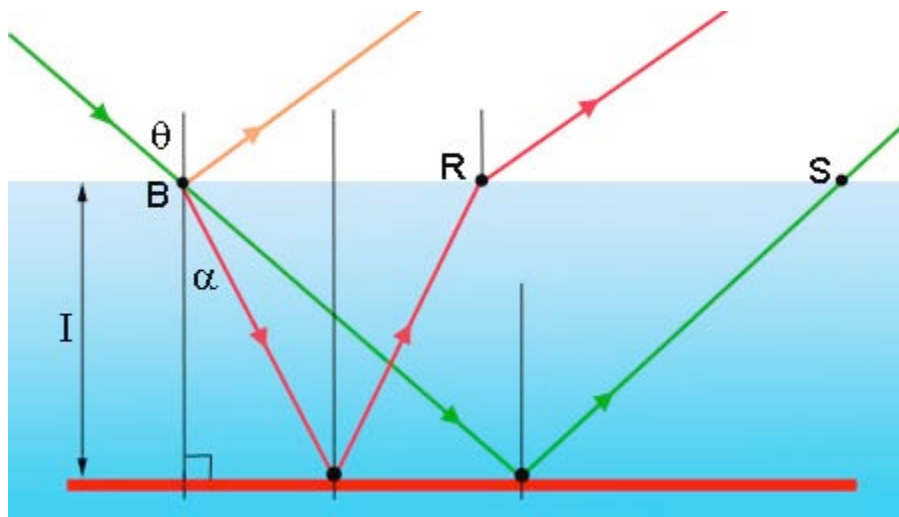

Simple geometry should allow you to calculate RI. The three rays will strike the wall some distance away. Note this distance and the height of the laser spots.

- **Refractive Index and Concentration**

A *mirage* is where you see an object that is on the ground in the distance but it looks like it is either floating above the ground or reflected off the surface. It is a result of the different densities of air above the surface caused by heating (as above). However a similar effect can be seen when you shine a laser into a tank containing concentrated sugar solution on to which a layer of water has been gently poured; the light bends down towards the more concentrated region. A good EEI would be similar to the one above but to vary the concentration of solute rather than temperature. Some experiments seems to show a linear relationship for sugar and others a curve (who to believe?). Others show a linear relationship for a while and then a curve. An interesting paper by physicists Yunis and Rahman from the University of Agriculture, Malaysia published in Applied Optics (V27 (16), 1988 has some good practical ideas ([click here](#) to download). I also read on one site "I think it's worth bearing in mind that the refractive index is mostly a matter of dielectric constant so it typically has a lot to do with the electric charges in the material". That suggests a comparison of ionic (sodium chloride) vs molecular (sugar) solutes; or even monoprotic (Na^+) vs diprotic (Mg^{2+}) ionic solutes.

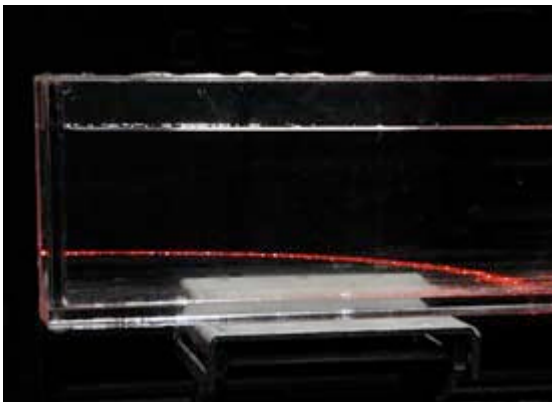

See how the laser beam bends down as it travels through a sugar solution with a high density at the bottom.

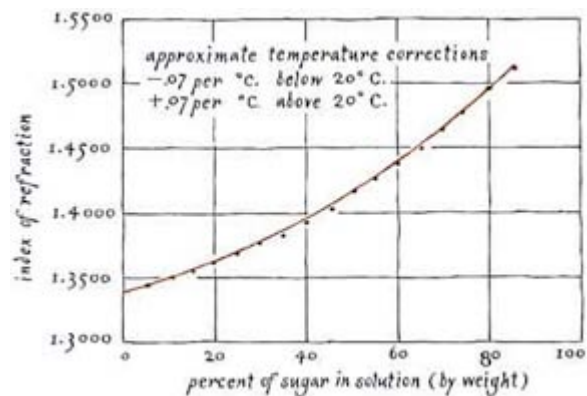

One student's results show a non-linear relationship for sugar but this is not what everyone gets.

- **Magnetic Field Strength and Temperature**

You may have tried an experiment where you magnetised a nail by rubbing it with a magnet and then when the nail was heated it lost its magnetism. Magnetic Field Strength is affected by temperature. This makes an ideal EEI. In his Year 12 EEI at Villanova College, Coorparoo, Brisbane, student Peter Bergin wrote:

"When the magnet is cooled, the borders of the domains slightly move so that the alignment of the domains are further preferential and create a stronger magnet. If the temperature of a magnet is raised, it causes the random thermal motion of the atoms to increase. This motion randomises the domains and the borders are shifted so that they are no longer in a complete single direction like the domains were previous to heating". He used a Hall Effect field strength probe as shown in the photo below. Peter found a field strength of 45.2 mT at -25°C down to 43.8 mT at 20°C . He suggested liquid nitrogen would be interesting. The EEI may be strengthened by a more direct measurement of the field strength. Rather than a "black box" probe, you could estimate the field by measuring the torque on a compass needle or by the rate of oscillation of another magnet swinging in the field nearby (as they did in the olden days). A comparison of different types of magnets, or length of heating time or different ways of measuring B would be worthwhile.



Peter Bergin's design



The Hall Effect probe may be better replaced with a less sophisticated device.

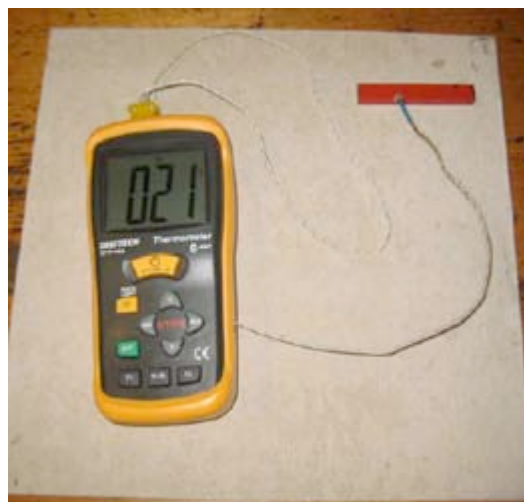

Measuring temperature

The Thermocouple

One device used widely used in science, industry and medicine to measure temperature is called a thermocouple. It consists of two wires of two different materials that are joined at each end. When these two junctions are kept at different temperatures a small voltage occurs. This voltage drop depends on the temperature difference between the two junctions. The phenomenon is called *Seebeck Effect*. The measurement of the voltage drop (or emf) can then be correlated to this temperature difference.

Thermocouples are among the easiest temperature sensors to use and are very popular because they're generally very accurate and can operate over a huge range of really hot and cold temperatures. Since they generate electric currents, they're also useful for making automated measurements. Be warned about information you get off the internet about thermocouples. One popular site says a thermocouple is "...a junction of dissimilar metals that creates a voltage you can relate to temperature." This misinformation continues to appear on company web sites, in application notes, and in articles. You could make a simple thermocouple from copper and iron wire (see diagram below) using boiling water and icy water to calibrate your device. Then you could investigate the cooling curve (and time constant) when the hot end is allowed to cool in a gentle breeze. Or you could look at ways of forming the junction (twisting,

soldering, welding). Or how about different alloys and what factors influence the voltage (resistivity perhaps). There are lots of things that would make a great EEI.

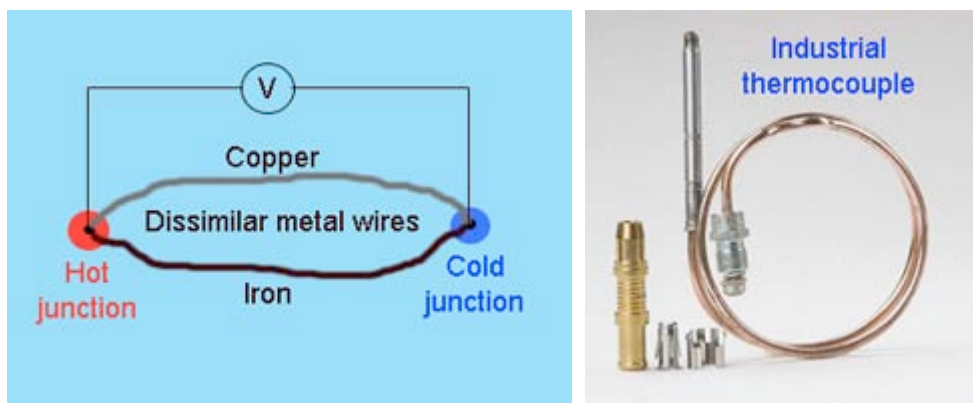

• **Surface Tension of Water - Tate's Law**

You've seen water bugs standing on the surface of water. We can't - so how come they can? The property of liquids - surface tension - is critical in all of our lives from the control of it in our bloodstream to large scale engineering applications. Year 12 student at Villanova College, Coorparoo, Brisbane, David Thompson chose to investigate this phenomenon for his EEI in consultation with his Physics teacher. David wrote "This experiment aimed at investigating the surface tension of water at different temperatures and with detergent. It was thought that an increase in temperature would result in a linear decrease in surface tension and that the addition of detergent would reduce the surface tension of plain water to about a third of its strength. The surface tension was measured using a suitable needle and dripping a liquid from it, inspired by Italian physicist Gianino Concetto". He relied on Tate's Law that says when a drop falls from an orifice (like a syringe needle) $\pi d\Gamma = mg$ (where Γ is the surface tension). The rest you can find elsewhere. You have to ask: how do I measure the mass of a single drop and the diameter of the needle? At 293K David was getting drops with a mass of 1.48×10^{-5} kg and at 313K 1.36×10^{-5} kg. Surface tension was about 60 mN m^{-1} . Over to you.

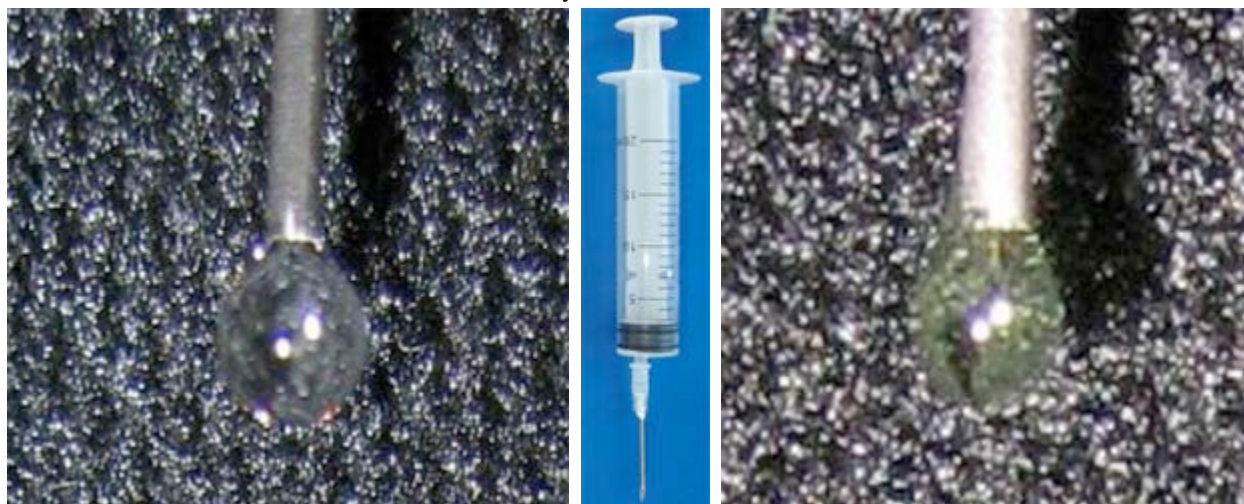

A water droplet about to fall

Syringe

Oil droplet. Photos by David Thompson.

- **The World's Simplest Motor**

The "Homopolar Motor" has to be the world's simplest. It was invented in 1821 by Michael Faraday. You'll find ones on *You Tube* purporting to be simple but not as cool as the one below. "How does it work?" was set for the 2009 IYPT competition in China. Briefly, (and I don't want to give you too much help) when you touch the wire to the side of the magnet, you complete an electric circuit. Current flows out of the battery, down the screw, s***** through the magnet to the wire, and through the wire to the other end of the battery. The magnetic field from the magnet is oriented through its **** faces, so it is ***** to the magnet's axis of symmetry. Electric current flows through the magnet (on average) in the direction from the centre of the magnet to the ****, so it flows in the ***** direction, perpendicular to the magnet's axis of symmetry and <snip> so the magnet begins to spin. Neat! For an EEI you could investigate angular speed vs voltage etc. Think stroboscope when you think speed. There's a good article in *The Physics Teacher*, February 2005. Somewhat surprisingly, this is more than just a curiosity: motors of this design are currently being developed for quiet, high-power applications.

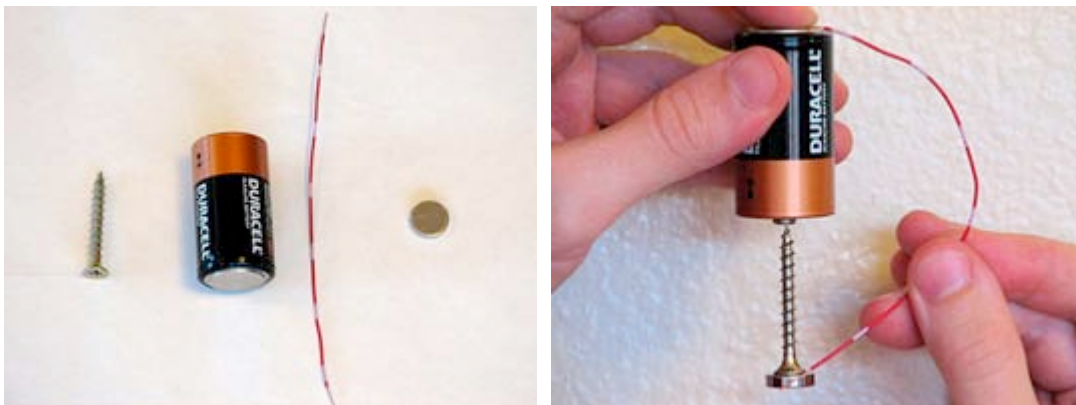

- **Roof colours - white vs black**

Nobel laureate Steven Chu, former professor of physics at the University of California and now U.S. Energy Secretary in President Obama's administration says "white paint is what's needed to fix global warming". However, Steven Chu said, even if we paint every roof white, "there was no silver bullet for tackling climate change, and said a range of measures should be introduced, including painting flat roofs white. Making roads and roofs a paler color could have the equivalent effect of taking every car in the world off the road for 11 years." That sounds like an ideal EEI. One Australian company sells just the thing: *White Roof Shield* is a white coating which reflects 80% of the sun's radiation. They say it "helps reduce interior cooling loads of air conditioned structures, resulting in savings of both energy and money. Even buildings without air conditioning stay cooler because roof surface temperatures are significantly reduced". Put some roofs of different amounts of whiteness in the sun for some time and measure the temperature of something underneath (maybe air, water). Maybe a heating curve is best. May need more than three trials, and what's the best way to produce this (mixing black and white paint proportionally, black masking tape etc). What about flat paint vs satin vs glossy?

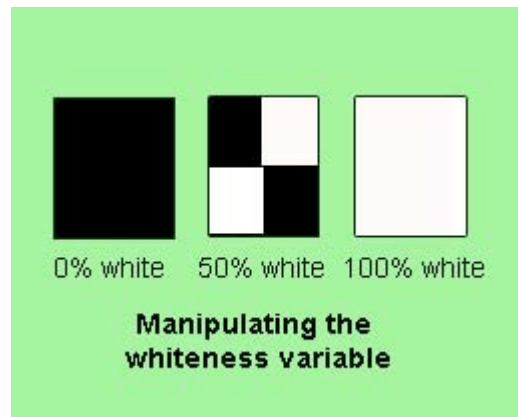

- **Tennis Racquet - Sweet and other spots**

On the face of the tennis racquet, there are several points that are important to players; these are the centre of percussion, the vibration node, the best serving spot, the best returning spot and the dead spot. A couple of the spots are shown on the diagram below. The centre of percussion is one of the two "sweet spots" of the racquet. This is because at the point of impact between the centre of percussion and the ball, the hand can feel no impact. This is due to the fact that the centre of percussion is located near the centre of the face of the racquet. You can easily find out what all this means and about the other sweet spot. A good EEI would be to test the 'coefficient of restitution' (ratio of bounce height to drop height) of different parts of the face. Perhaps clamp the racquet in a vice and drop a tennis ball on different position of the face and noting bounce height as a fraction of drop height. Does drop height affect the coefficient of restitution? Is the type of ball important? Does a temperature change shift the sweet spots? Are new racquets better than old? Is aluminium better than graphite? Does string tension play any part? The possibilities are endless. The photos of professional players show that the serving spot is high and the return spot is low. Note: Brad Barker from Carmel College has listed "Physics of Sport EEIs" that have worked at his school. [Click here](#) to download.

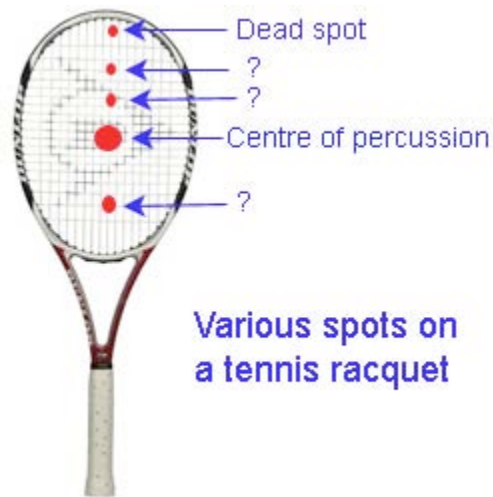

- **Danger inside a hot car**

After rescuing 20% more children from locked cars last summer than the previous year the Royal Automobile Club of Queensland has urged parents not to leave children locked in cars. The RACQ says that on a typical Australian summer day, the temperature inside a parked car can be 30° - 40°C hotter than outside the car. That means that on a 30°C day, the temperature inside the car could be as high as 70°C and 75% of the temperature increase occurs within five minutes of closing the car. They also say that darker-coloured cars can reach a slightly higher temperatures than lighter-coloured cars (I would have though much higher temperatures); and that large cars can heat up just as fast as small cars. The key variables are obvious for an EEI and having a data logger would be great. But some others worth considering are the colour of interior trim; having the windows down a bit, or even fully open; dark vs light colours; big vs small; time of day (angle of sun); and window tinting. You could even model a car by using painted soft-drink cans and sealing a thermometer into the hole with Blu-tac. Maybe you could puncture holes in the side to represent an open window (or vary the number of holes as a manipulated variable). Oh, the possibilities are endless but and it looks easy but controlling the variables will be important.



Air Cannon

Projectiles such as tennis balls, oranges and potatoes can be launched from a plastic pipe using compressed air. The device is called an air cannon and relies on a cylinder of air compressed with a bicycle pump being quickly released into a smaller plastic barrel via a quick-acting valve (hand operated or solenoid). There are many designs on the internet but for the purposes of a good EEI a small cannon should be made and the pressure restricted to a maximum gauge pressure of about 30 psi (200 kPa) for safety. You could examine the effect of pressure, barrel length and diameter on distance. Most of the designs on the internet look dangerous and may be classified as a Category B Muzzle Loading firearm under the Queensland Weapons Act (1990) because it could do "bodily harm" (bruising) so negotiate the design and safety considerations with your teacher (see "[weapons](#)" note above). If in doubt - don't do it.

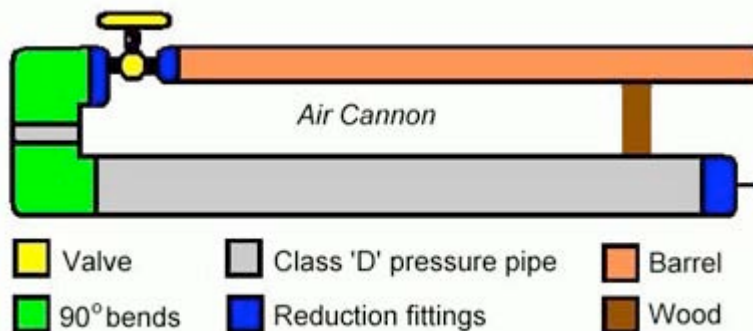

- **Another air cannon**

The photos below show the design of a typical air cannon. The rule here is simple, if you can't carry this out safely after having done a risk assessment, including arranging appropriate adult supervision, and meeting any legal requirements - don't even think about it. In fact, in Queensland, a compressed air gun like this is classified as a Category B Muzzle Loading firearm under the Queensland Weapons Act (1990) because it could do "bodily harm" (bruising) so negotiate the design and safety considerations with your teacher (see "[weapons](#)" note above). If in doubt - don't do it. It could be that it can only be used by a person with a Category A/B firearms license, either on a range or in a rural area with a property owner's permission. To anyone considering it, check before a breach of the Act is committed. It would seem very dangerous though - a small fracture in the pipe, a manufacturing flaw, or a weakened area around the solvent adhesive, etc could result in sharp fragments travelling in unpredictable directions. Under the Education Queensland guidelines it would (probably) be classified as an "Extreme" risk activity that needed parent consent and the Principal to sign off on the risk assessment.



The masterpiece. **To see an enlarged view, click the image.**



Pump up to 60 psi



Pump nozzle



The expensive valve



The valve closed



The valve open and whoosh

- **Air powered potato cannon**

The other popular type of cannon based on the above design is the potato cannon. The details are easy to find on the internet. I was thinking that a good EEI would be to measure the range of a projectile when the cannon is free to move (on wheels) or placed against a tree. Soldiers know very well that if you place your cannon against the base of a tree you get better range. When a cannon is fired (restrained or free to move) the change in momentum is zero, hence, $mv_0 \cos\theta - MV_0 = 0$. If the work done by the expanding gases (W) is converted into the kinetic energy of the cannon ($\frac{1}{2}MV_0^2$) and the projectile ($\frac{1}{2}mv_0^2$), thus: $\frac{1}{2}mv_0^2 + \frac{1}{2}MV_0^2 = W$. Hence by combining the equations: $\frac{1}{2}mv_0^2 + \frac{1}{2}(mv_0 \cos\theta)^2/2M = W$. If the cannon is constrained the formula becomes: $\frac{1}{2}mv_0^2 + \frac{1}{2}MV_0^2 = W - U$ where U is the work done on the constraining

tree. The rest of the equations take too long to code for this webpage so you should have a look at the linked article: [Cannon recoil against tree](#). I'd be looking at whether the recoil adds a certain % increase in range or whether the elevation matters and so on. You should also see the "[weapons](#)" note above.



Put the cannon on wheels and compare it to one staked to the ground.

- **"Windage" and air cannons**

To propel a projectile such as a cannon ball up a barrel it is essential that the compressed air doing the pushing can't escape around the sides of the ball. However, in the early days, because of irregularities in the size of cannon balls and the difficulty of boring out gun barrels there was usually a considerable gap between the ball and the bore - often as much as 5 mm - with a consequent loss of efficiency. This gap was known as the "windage". The windage of the guns was eventually standardised by trial-and-error: the bore diameter was to be $21/20$ of the gun's round shot diameter. As manufacturing precision became greater it was reduced to $25/24$. On the SBS program "Engineering Connections" Richard Hammond explained that windage was important in car engines too. There should be a minimum gap between piston and cylinder. He fired two projectiles out of an air cannon to show the effect of decreased windage (the one with smaller windage went 25% further in range). A good EEI would be to compare the effect of windage on projectile range (keeping everything else constant). The projectiles would have to have the same mass but perhaps you could make some wooden cylinders of slightly different diameters on the school's wood lathe (but how would you keep the mass the same?). Over to you.



With the cannon ball placed in the barrel you can see the small gap.



Close-up of the windage (about 8 mm).

- **Nerf Gun ballistics**

You certainly don't need a weapons license for a Nerf Gun. They are available at big toy shops like Big W and Target for a cheapish price. The Nerf Gun fires foam projectiles up to about 11 metres. For an EEI you don't need lots of power and range, you need something that has a convenient range to measure accurately, and something in which variables can be controlled. There are many Nerf Guns on the market - from about \$12 to \$49. There is no point in getting a battery operated *Nerf Maverick* for \$12.95 that shoots like a machine gun (except if you're playing *Humans vs Zombies* on Halloween). Better to get the *Nerf-N-Strike Longshot Blaster* for \$49 which does a single shot from a long (90 cm) barrel a distance of about 10 m. You can vary the mass of the projectile by pushing weights into the foam, or you could alter the barrel length. Your main problem is how do you keep the pressure constant from trial to trial. Although a *Nerf Gun* could be considered a Muzzle Loading device under the Queensland Weapons Act it would not be considered a "firearm" as it could not do "bodily harm" (bruising). You should see the "[weapons](#)" note above.



The *Nerf N-Strike Maverick* is cheap (\$12) but the quick-firing is not much use in Physics unless *Zombies* are on the loose.



A much better option for a Physics EEI is the *Nerf N-Strike Longshot CS-6* for about \$45. Also a great present for your Physics teacher.

- **Sliding off a roof**

Particularly in colder climates, the problem of objects sliding off a roof is a big problem - mainly snow and ice - and many steps are taken to ensure this happens in a controlled way. A similar situation arises in amusement parks - particularly water slides - where the designers need to calculate the landing position of a person for a given incline angle, friction, and height of the launch point above the ground. For the diagram below the relationship is: $m g L \sin\theta - \mu m g L \cos\theta = \frac{1}{2} m v^2$. From this you can calculate launch velocity and hence horizontal range on landing. You could do a great EEI by considering these factors and seeing how they relate to your experimental data. What angle gives the greatest range - and why; and is this for all coefficients of friction? You could also consider a rolling object but rotational kinetic energy would also have to be considered.

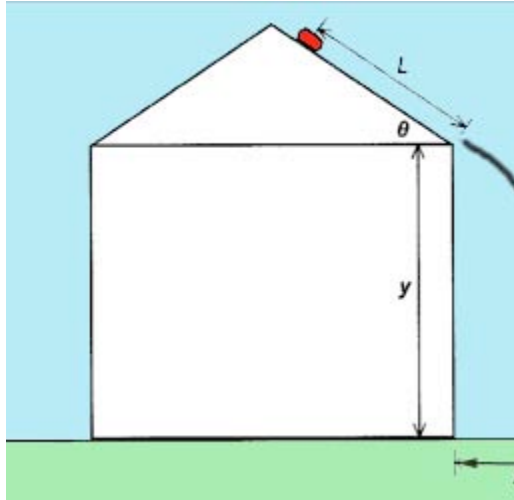

Observations to be made



An EEI that is going to end in tragedy.



Stanthorpe State High School perhaps.

- **Measuring projectile velocity acoustically**

In the two experiments above, the range of the projectile is considered to be a measure of the velocity of the projectile. A neat EEI would be to compare methods of velocity estimation rather than just the factors that influence the range. I have seen an interesting method in *The Physics Teacher* (Nov 2007, Volume 45, (8), pp. 496) in which a microphone hooked up to LoggerPro or some other data recorder is used to measure the time elapsed from the initial explosion to the time taken for the sound to return from the target. You need a big metallic target like a thick sheet of aluminium placed say 10 metres away. Once the projectile strikes the target the sound is returned to the microphone at the barrel (muzzle) of the cannon. You get a waveform like the one below. The first part is saturated by the gas pressure as the projectile rushes up the barrel and the second point is when the sound returns to the microphone from the target. If you can work out the speed of sound you can subtract the time for the sound to return from the time after the ball leaves the cannon. $v = s/t$ and you have your answer. Is this more reliable than a measure of range? How does range method and the acoustic method compare? Which is less prone to errors? Could you try 20 m rather than 10m? The possibilities are endless.

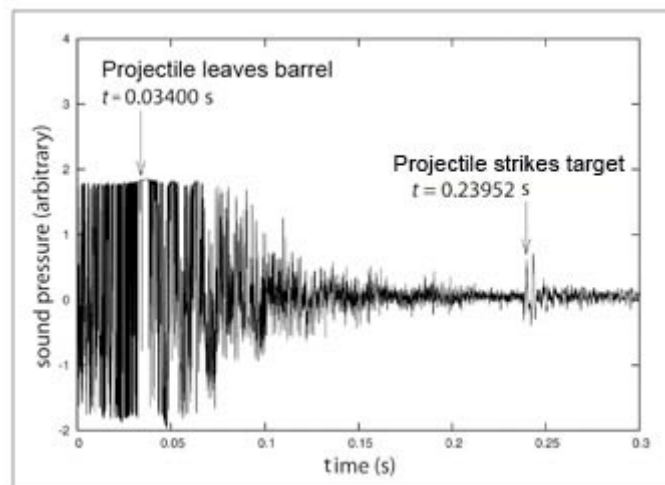

- **Parachute descent and mass.**

Parachutes are not only used for sport but for dropping soldiers into war zones and delivering food and medicine to flood and drought ravaged countries. Even though they've been around for several hundred years it wasn't until after WW2 that the apex vent was invented. You could do an EEI to find out how drop time is affected by mass, canopy area, size of apex vent, number or length of strings, canopy shape and so on. That's Genevieve Ash on the right having a bit too much fun. [Click here](#) to download Moreton Bay College's Year 10 Parachute EEI task.



Parachute terms



Genevieve Ash doing her EEI at Moreton Bay College in 2009

- **Arrow range and draw**

A bow is a device that converts slow and steady human force over a distance (Work) into stored Elastic Potential Energy (in the form of tension in the Bowstave, Limbs, or Prod). This energy is converted into Kinetic Energy upon release of the Bowstring, and a great deal of that kinetic energy is transferred to the arrow. A bow is basically a spring which stores energy to be put into the arrow. However, 'draw' is not necessarily proportional to the force applied; and therein lies the complication. You could examine range vs. draw for an interesting EEI. You could consider a comparison of velocity by ballistic pendulum and by the range formula. A bow and arrow is not considered a "weapon" under the Queensland Weapons Act (even though it could be lethal - but so could a baseball bat or kitchen knife). It only becomes a "weapon" when used for a "behavioural offence" such as attacking a person. You should see the "[weapons](#)" note above.

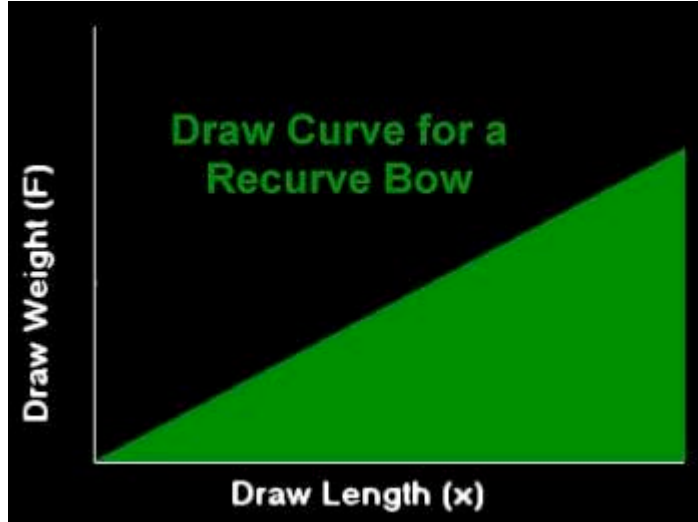
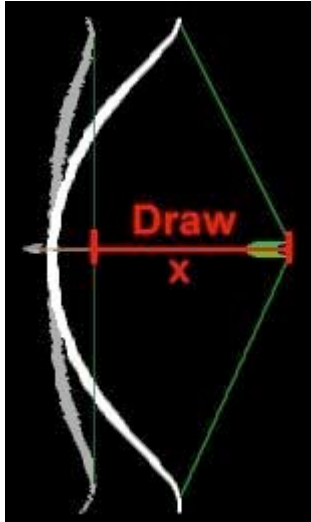

- **Arrow elevation and range**

When you fire an arrow from a bow you will see that different angles of elevation give different ranges. In a vacuum it can be seen that the maximum range occurs for an elevation of 45° . However, in air, the range and elevation are not related so simply (see the two graphs below). This suggests several good EEs. You could merely find out which elevation gives the best range when "draw" is kept constant, but you could also propose an hypothesis along the lines of " 45° gives the greatest range" and that angles above or below this give a shorter range. Further, complementary angles are said to give the same range - but this could be tested (see diagram below). Lastly - is "range" the only dependent variable you want to look at. Perhaps an archer is more interested in "time of flight" as this may give better accuracy (less time for air resistance to apply). I have attached two pages from my *New Century Senior Physics* text that may be helpful in designing this experiment. [Click here](#) to download them.

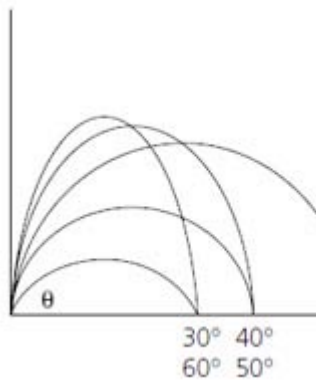

Theoretical path of a projectile (in a vacuum). Complementary angles seem to give the same range - but is this true in practice?

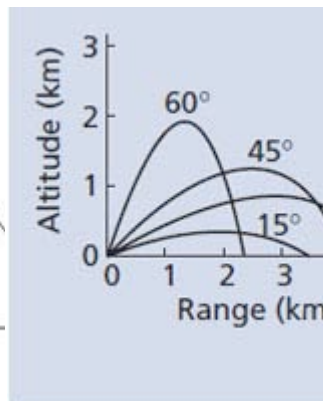

In air the path is somewhat different. This is for a cannon shell going to great heights - not an arrow.

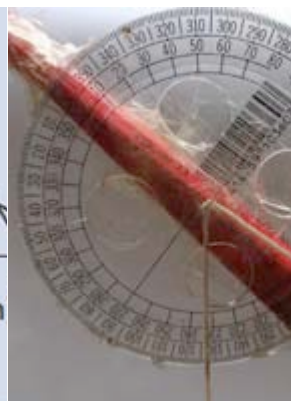

A protractor stuck to the bow and with a brass bob hanging down is one way of measuring the elevation angle.



Practice firing by Year 11 Physics students at Wellington Point SHS, Queensland.

- **Arrow accuracy and tail fletches**

Tail fletches are the feathers on the ends of arrows. You could do an accuracy comparison of Bulldog,

Native and Pope & Young fletches; or you could try setting the fletches straight with no offset, straight with an offset, or left and right helical fletching. The combinations are enormous. You could investigate the errors with different fletches; why? What's the hypothesis? What is important - range or accuracy & why?

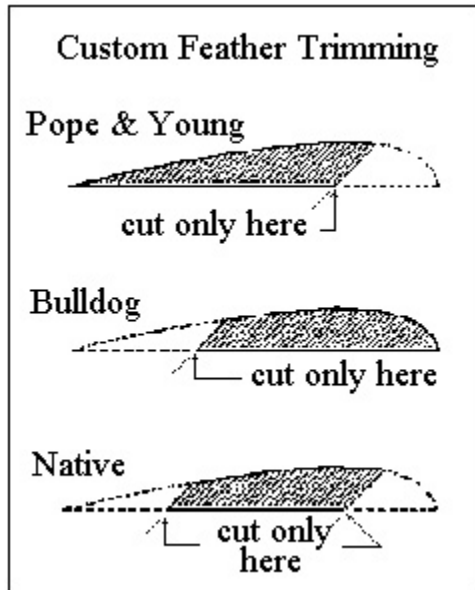

Three common methods of trimming feathers.

Remember - the string on a Recurve Bow goes on the outside of the curve. Students often get this wrong.

One way to measure long ranges. But how accurate is it?

• **Slingshot range and draw**

You could always make your own slingshot and test out how it goes for different angles and amount of draw (pull-back). One student (Jack) at Kuranda State High School (North Queensland) made a huge slingshot using steel waterpipe and 8 mm thick speargun rubber. He worked out the spring constant in the classroom and then looked at conservation of mechanical energy in his big slingshot on the oval. He varied *angle*, *draw* and *mass* of projectile as his independent variables; and *range* was the dependent variable. The photos below came from his EEI. My thanks to his Physics teacher Ruth Moxon for getting Jack's permission to use these photos. Note: Slingshots are not "firearms" at present under the Queensland Weapons Act 1990 but there is a concern that commercial slingshots can be lethal. Of particular concern to police is the *Saunders Falcon 2 Wrist Rocket Slingshot* type which can be quite lethal. It may be described as a weapon in changes to the Act (you should check; and you should see the "[weapons](#)" note above). The one shown in these photos is not likely to be of any concern under the Act.



- **Measuring "g" using falling nuts**

Most attempts to measure the acceleration due to gravity end in disappointment as the errors in timing or from friction are a big problem. This suggestion requires the use of a set of steel nuts tied together with string at set intervals, and a microphone and CRO. Basically, you hold the nuts-on-a-string vertically and drop them on to an aluminium pie plate. The impact sounds are captured as a series of peaks on the CRO which allows you to measure the time intervals. The diagram below shows the setup. If you don't have a CRO in the lab, download a free sound analyser (*Audacity* or *Scope* for example). [Click here](#) to see my note about computer CROs further down the page. As it stands you have an experiment that could be done in the lab in a double lesson. Is this good enough for an EEI? No, you'll need to extend it so that you are using an hypothesis of some sort to guide your development of a procedure that extends the idea of measuring **g** with falling nuts. You could investigate ways to improve the accuracy of the method, you could look at the relationship between the measurement of **g** and other variables (weight of nut, spacing of nuts and so on). To get an "A" requires a carefully thought out plan of manipulating variables and detailed examination of all the uncertainties and errors you've coped with. Good luck. Get plenty of photos.



- **Speed of sound in air as a function of temperature**

For his Year 11 EEI Chamara Perera from Wynnum State High School (Brisbane) made use of the coldroom at MacDonalds where he worked after school. Here's what he said: *"The pictures (below) show the length of PVC pipe placed on a piece of ceramic tile (to ensure a crisp echo), with the microphone*

placed at the opening of the pipe. I found that the click of a pen worked really well when used to make the noise to echo, registered very clearly on the computer. The older version of the program 'Audacity' was used as the recording program, I say older program because that one measured down to more significant figures whereas the new doesn't. Measurement was then taken from the peak of the first registered noise to the peak of the second. To vary temperature, I took this very apparatus to the fridge at work which was about 5 °C, the freezer at work, -21°C, outside on a cold night, about 11°C, up into my roof on a hot day about 30°C and finally just at room temperature, about 24°C. All temperatures were measured very accurately using a temperature probe and the program Logger Pro 3.4.5". The questions you could ask are: did you try other lengths of pipe; was the frequency of the sound important; did you try other independent variables; what was the source of any errors; is there a phase change upon reflection and is this a problem, what are the limitations of the experiment; why is this important to you and to society...and so on.



Full setup

Making the click

The reflecting end

• **Guitar Pickup**

The electric guitar pickup works on electromagnetic induction principles. A magnet inside a coil induces magnetism in a steel string nearby and when the string moves...voila! A humbucker is a modified pickup that has two coils in opposition to reduce the effect of stray AC signals. You could model a pickup and test the effect of spacing, magnet strength, coil windings, size of string etc; and then test the ability of a humbucker to reject external noise. I told my students that Jimi Hendrix used to rewind his pickup coils to make them more sensitive. The students said "who's he?".

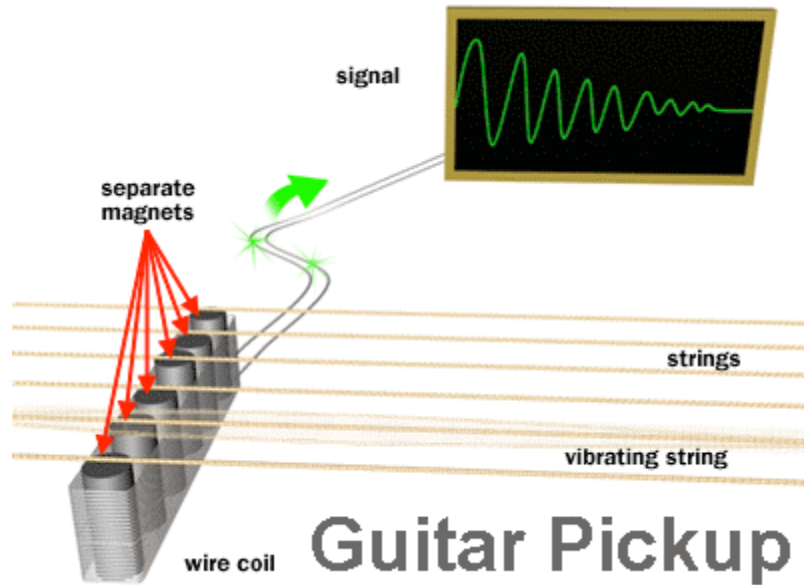

Guitar Pickup



Gibson Humbucker

- **Factors affecting the frequency of an organ pipe**

This is another music-related investigation you could undertake - but it also applies to the exhausts of motor cars and bikes; for example, auto engineers make the exhaust pipes such that they resonate at certain desirable frequencies. For some V8s with a separate tailpipe from each bank of cylinders they run a 60mm pipe down each side and put a 50mm pipe joining them to generate beautiful beats. So organ pipe physics is used all over the place! Why not investigate end correction for different wavelengths and diameters of a simple pipe (eg PVC plumbing pipe); and for open and closed pipes. How does temperature play a part?



Church Organ Pipes



MagnaFlow Resonators



Cross pipe for beats

The reverberation time of a large hall

You are probably familiar with the way some rooms echo whereas others always sound really quiet. The best measure of this acoustic property of a room is known as reverberation time. Reverberation is the persistence of sound in a particular space after the original sound is removed. A reverberation, or reverb, is created when a sound is produced in an enclosed space causing a large number of echoes to build up and then slowly decay as the sound is absorbed by the walls and air. The reverberation time (RT_{60}) is the time required for reflections of a direct sound to decay by 60 dB below the level of the direct sound. The reverberation time receives special consideration in the architectural design of large chambers, which need to have specific reverberation times to achieve optimum performance for their intended activity. This makes a great EEI. Not only can you measure the reverberation time of a number of different rooms (laboratory, classroom, large lecture hall, auditorium, sports hall) but you can make measurements from different parts of the room. Best of all, you can calculate the theoretical value for RT_{60} using the formula $RT_{60} = 0.161V / S(a \times s)$ where V is the volume of the room in m^3 , a is the area of each absorbing material in m^2 , and s is the absorption coefficient for each material. All you need is a stopwatch, a ruler, a sound pressure sensor (connected to a computer is good) and something to make a loud noise. Toni Tran from Victoria Point SHS popped balloons with a pin for her sound source and her RT_{60} values were: hall 1.5 s, classroom 1.0 s, sports hall 1.8 s and so on.

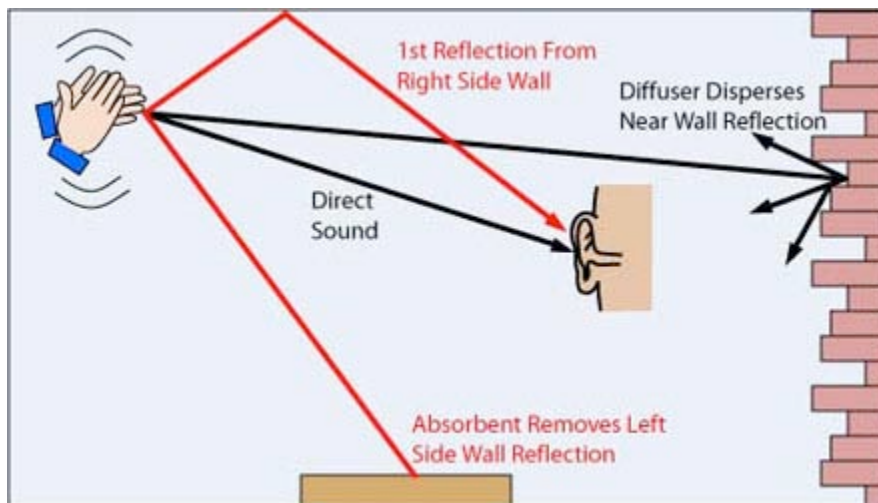

- **Spacing between successive turns of a slinky suspended vertically under its own weight**

Here's a good one if you like playing with toys. When suspended vertically, a slinky will stretch enormously even under its own weight, its extension being tens of times greater than its undistorted length L_0 when not hung, depending on the size and material of the toy. Here are two suggestions:

Suggestion 1. Suspend the slinky from any turn along its length and let the rest of the n turns below it dangle freely. Then measure the free-hanging length as a function of the number of turns in it, $L(n)$. Physicists have calculated that $L(n) = (mg/2k)n^2$ where k and m are the force constant and mass of a single turn, respectively. See reference below.

Suggestion 2: choose a slinky such that when suspended from the ceiling freely it stretches nearly all the way to the floor (a longer one may be cut to size). Measure the distance from the bottom end as a function of the number of turns, $y(n)$, as you advance up from the bottom of the slinky (L_0 is the full length of the stretched spring; L = length of the spring unstretched (lying on it's side), y = distance from bottom up to turn n ; N = total number of turns. Physicists have derived a formula for this:

$$y(n) = \frac{L_0}{N}n + \frac{L - L_0}{N^2}n^2.$$

For either: What is the effect of added mass; why would anyone want to know this - what's the point? Compare a steel and plastic slinky. How do their spring constants vary? Source: Paul Gluck (2010). A project on soft springs and the slinky: *Physics Education* V45(2), p 180.

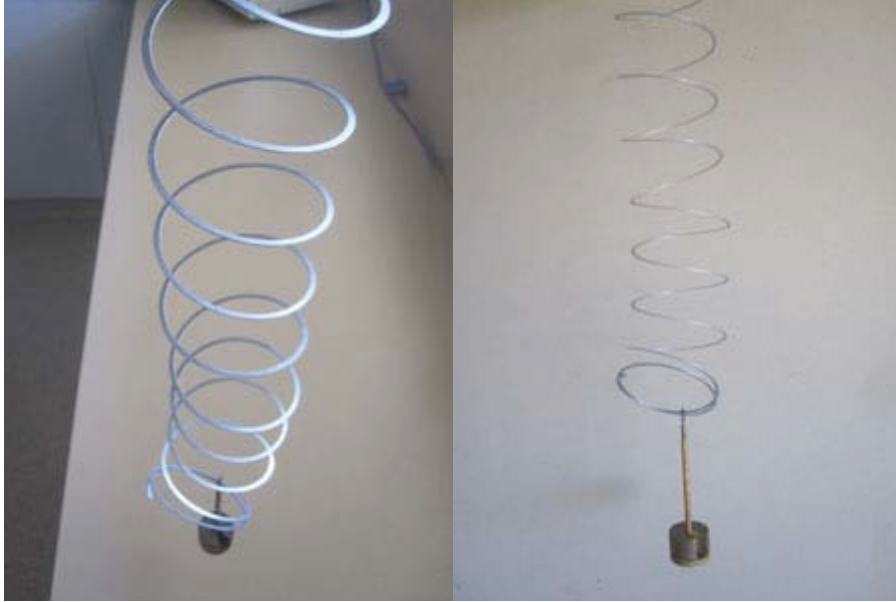

- **Magnetic Field in a Slinky**

The availability of inexpensive Hall Effect magnetic field probes enables an interesting EEI to be done into the magnetic field strength inside a slinky. You can insert the probe between adjacent turns (see photo below) and measure the field as a function of the distance between turns (or turns/metre). For a second variable you could try changing the current or placing the probe at different distances from the centre. However, if you don't have a Hall Effect probe (eg from Vernier Software) and want to make your own there is a good article (for download) in [Physics Education V45\(5\), September 2010, page 529.](#)

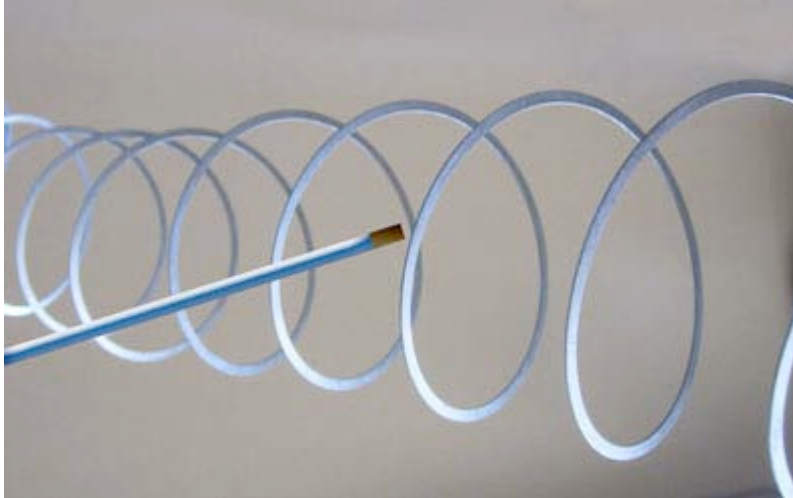

- **Hertzian Waves**

Many early experiments with radio used sparks as detectors and as sources of electromagnetic radiation. A good EEI would be to investigate the electromagnetic nature of radio waves. You could find out if the strength of the signal decreases of intensity with distance from the transmitter, and to investigate electromagnetic shielding. One way would be to tune a transistor radio (not digital) between stations. The radio almost certainly has an automatic gain control and so will be more sensitive when tuned between stations. However the background noise - also broadband noise - will be stronger too. Hold one end of the wire to one end of a 1.5V battery. With the other end of the wire briefly scrape the surface of the other battery terminal, making sparks that will be visible in dim light. You could use a CRO to measure the loudness of the crackle on the radio. What happens with distance, voltage of the transmitter, shielding

(paper, metal, glass) between transmitter and receiver.

Hertzian Waves



Speed of Sound in a Metal Rod (see four approaches below).

An experiment commonly used in first year physics at university is to determine the speed of sound in a metal rod. If you use metal rod clamped at the centre, standing waves can be formed in the rod by striking one end of the bar (end on) with a hammer. Since the bar is clamped at its mid-point a node forms there while antinodes form at the free ends as shown in the diagram. If the bar is vibrating in its fundamental mode, then the wavelength of the wave in the metal is equal to twice the length of the bar (L). So $f_{\text{air}} = f_{\text{rod}}$; hence $v_{\text{rod}} = f_{\text{rod}} \times \lambda = f_{\text{rod}} \times 2L$. You'll get a lot of (odd, 3rd, 5th, 7th ...) harmonics thrown in but the fundamental should be the strongest. So what variables are you going to manipulate to make a great EEI. Some continuous variables are: Perhaps see if the velocity is constant for different lengths. Does temperature affect the speed? Some discrete variables to manipulate are: What about other nodal positions: can you suspend the rod to get the 2nd harmonic and how does the speed compare when it is vibrating in the 1st harmonic? What about other metals; what characteristic of metals (Young's Modulus perhaps) provides a continuous variable that can be tested. The error analysis for any of these will be so important. The following gives you some ideas about some techniques that may work well:

- **Speed of Sound in a Metal Rod 1 – Microphones and CRO.**

The frequency of the standing waves in the rod is equal to the frequency of the sound produced and this can be determined by using a microphone connected to a CRO, or if you have it, DataLogger Pro or similar. You'll get a lot of harmonics thrown in but the fundamental should be the strongest. So $f_{\text{air}} = f_{\text{rod}}$; hence $v_{\text{rod}} = f_{\text{rod}} \times \lambda = f_{\text{rod}} \times 2L$. You may be lucky enough to have access to a computer program that analyses the sound from the microphone (may have to amplify) and applies a Fast Fourier Transform technique (FFT) to convert the frequencies being received to a spectrum of amplitude vs. frequency: the largest peak amplitude being the fundamental frequency of the rod or bar. One student struck a problem with this method: she used a 20 cm rod of steel of 0.75 cm diameter and got a frequency of 2500 Hz using *LoggerPro*. This corresponds to a speed of sound in metal of 1000 m s^{-1} instead of 5000 m s^{-1} as expected. There's a great article in *Physics Education* about this (see caption below).

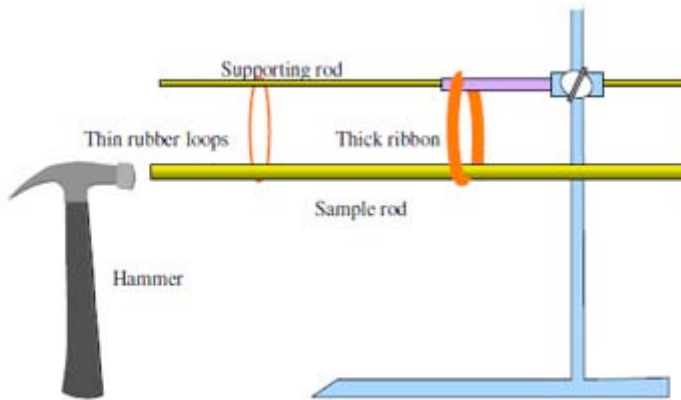

This diagram has been taken from a great article in [Physics Education 35\(6\) November 2000](#) entitled "Measurement of the speed of sound in a metal rod" by Se-yuen Mak, Yee-kong Ng and Kam-wah Wu from The Chinese University of Hong Kong, Shatin, NT, Hong Kong is attached for research purposes only (click link to download).

Paige Kurmass from Thuringowa State High School, Queensland, gives the thumbs up as everything is working in her EEI. She used apparatus as shown in the diagram to the left with different lengths of steel "reo-bar" and determined the effect of temperature on the speed of sound. In her Conclusion in the EEI she commented on the problem of reflection of sound waves from the walls of the lab, and problems in heating such long lengths of rod.

- **Speed of Sound in a Metal Rod 2 – Electromagnetic method**

Another good method is to use an iron or steel rod with a loose coil wrapped around one end. If the rod is slightly magnetized (as it is in the Earth's magnetic field), then the increased density at the compression maximum will be accompanied by an enhanced magnetization. When this region of higher magnetic field passes through a pickup coil placed around the rod (see Fig. 1), an EMF will be induced. The signal, consisting of a series of pulses, may be fed directly into an oscilloscope. This method is described in [The Physics Teacher V40, Jan 2002, p56-57](#) (attached for research purposes only - click to download).

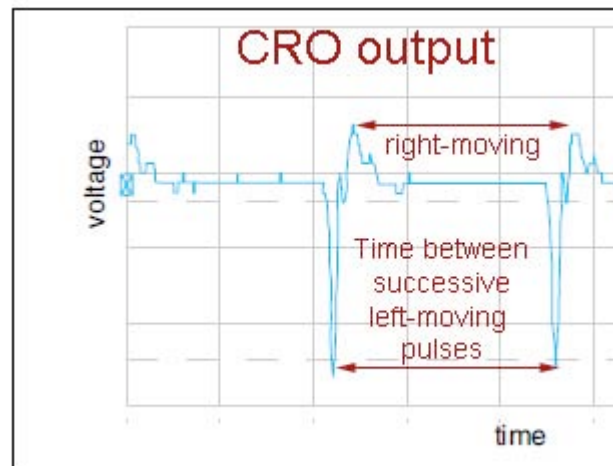
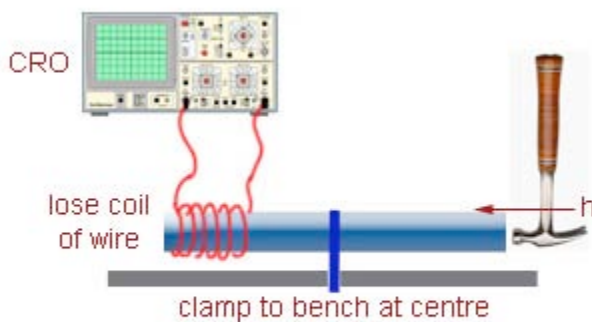

- **Speed of Sound in a Metal Rod 3 – Time of Flight method**

If you use a setup as in the diagram below and strike the end of the rod with a hammer, the CRO will

record the initial hammer strike (Channel 2), then the sound at the far end that has travelled through the rod (steel, about 5000 m s^{-1} for a longitudinal wave and about 600 m s^{-1} for a transverse wave) on Channel 1, then lastly the sound of the hammer blow that has travelled through the air (340 m s^{-1}) again on Channel 1.

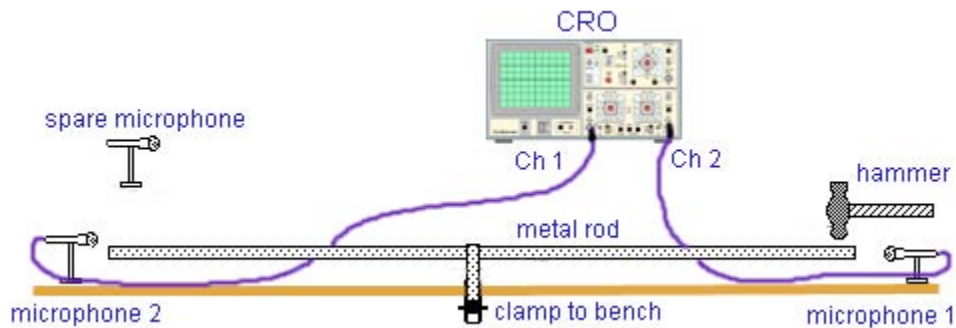

Hitting the rod laterally (on the side) as in this diagram will favour transverse waves ($v = 600 \text{ m s}^{-1}$ in steel). If you want to get longitudinal waves ($v = 5000 \text{ m s}^{-1}$) then you should hit the rod on its end.

• Speed of Sound in a Metal Rod 4 – Transverse Resonance.

The setup used in any of the suggestions above can be used to general transverse waves. To do that you have to hit the rod on the side near one end - at right angles to the rod. It will then vibrate like a tuning fork prong. The node will still be in the middle and you'll still get the first harmonic where $\lambda = 2L$. However, the speed of sound due to translational waves is about 1/8 of the longitudinal speed. There is a formula to work out the speed: $v = \sqrt{2\pi f c K}$ where $c = \sqrt{Y/\sigma}$ and Y is Young's Modulus for the metal ($200 \times 10^9 \text{ N m}^2$ for steel), and σ is density (7800 kg m^{-3} for steel) and $K = \text{radius}/2$. So for a steel rod 5 mm in diameter and 20 cm long: $v = 630 \text{ m s}^{-1}$ for a transverse wave. This is about one-eighth of the value for the longitudinal wave.

Note about CROs.

If you are after cheapish computer-based CROs you can get a Chinese 44MHz USB-CRO on ebay for about \$40 that looks pretty good. There is also a less-useful 5kHz one for \$25). However, there is also a free (to schools) software one called "Soundcard Scope" that uses the computer's line-in socket on the audio card. I have downloaded it and tried it out and it is quite remarkable. I struck a 440Hz tuning fork at the correct position for a pure tone and the software gave me 440.3 Hz. Not bad for a free CRO. It is written by Christian Zeitnitz from Germany and is available at http://www.zeitnitz.de/Christian/scope_en

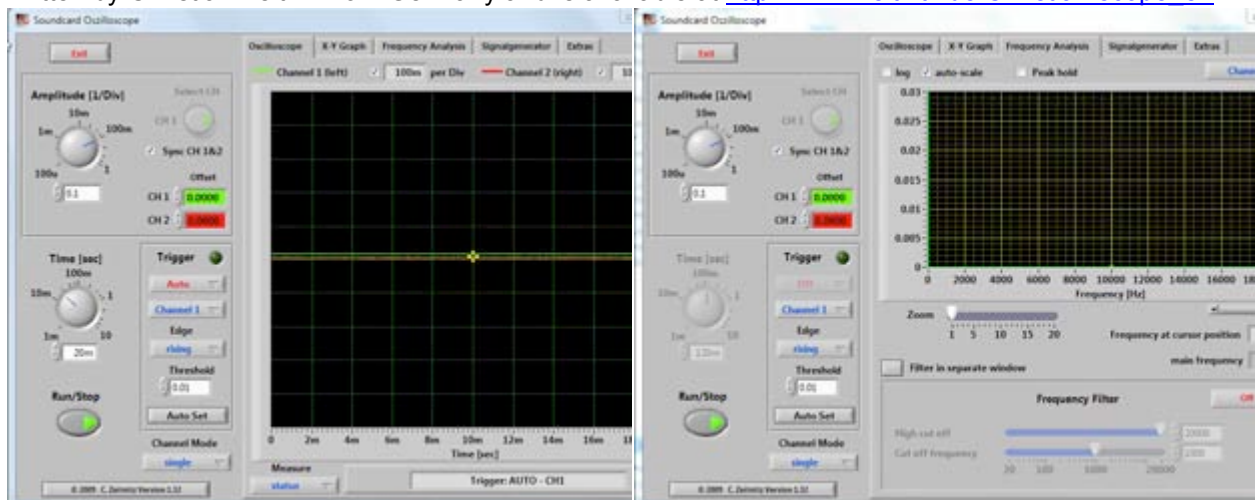

Soundcard Scope by Christian Zeitnitz - in voltage mode

Frequency analyser mode

I bought a bunch of 20mm diameter aluminium rods of varying lengths(1.8m down to 30 cm) from the local metal dealer (he cut the ends perfectly square as you need for "singing rod" experiments). I held them vertically at the middle (to cancel transverse waves) and struck them square on the end with a steel hammer and they "sang" beautifully. Using the microphone, I collected the signal on the CRO. It was a bit messy as it had many overtones present but when I used the "frequency analysis" option it showed the big fundamental and all of the overtones as a histogram. You could see the various overtones die away in real time. I did this for all of the rods and the calculated speed of sound in the rods was almost all identical. I plotted f (y-axis) vs $1/(2L)$ and the gradient is the velocity. I got 5035.76 m/s whereas the accepted value is 5091.8 m/s. There are many great EEI possibilities in this setup. PS: I bought my 20mm aluminium rod from Brisbane Steel Supplies at Capalaba for \$33.20 for a 4m length (cut to size for free).

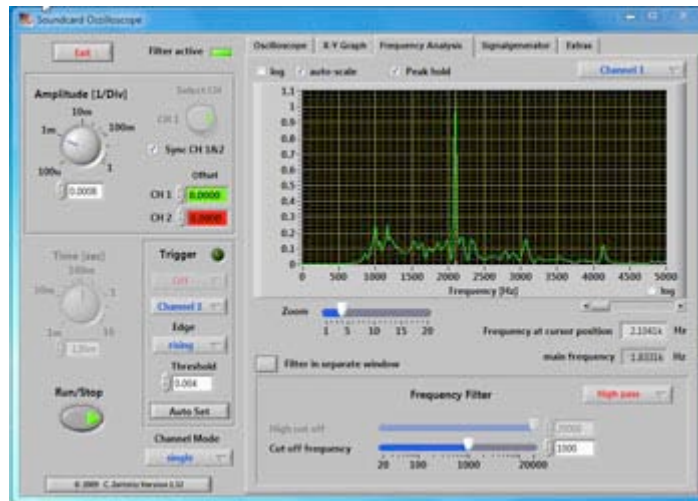

Here's a screen capture showing the fundamental frequency of a 1.200 m singing rod and a frequency of 2104 Hz. [Click here](#) to see a larger version plus some notes.

Speed of sound - resonance method

One of the important investigations carried out by professional scientists is to improve the accuracy of physical quantities such as specific heats, resistivity and so on. The National Physical Laboratory in London was set up in the early 1900s to do just that. As part of the investigation they look for errors in methods and try to minimize them. This idea can form the basis of many EEIs - that is to extend simple experiments by extending the range over which variables are measured or to improve accuracy in existing methods. One simple but excellent experiment is carried out in high school physics labs throughout the world: the measurement of the speed of sound by resonance, in which a tuning fork is held at the end of a close (at one end) tube and the tube's length varied until resonance (loudness) is heard (see photos below). The length of the tube can be varied by immersing it in water. A good EEI would be to measure the speed of sound using the first harmonic condition (pictured below) but trying it for a range of frequencies. Is there a relationship between frequency and the speed? If there is we have a problem

that bears investigating.

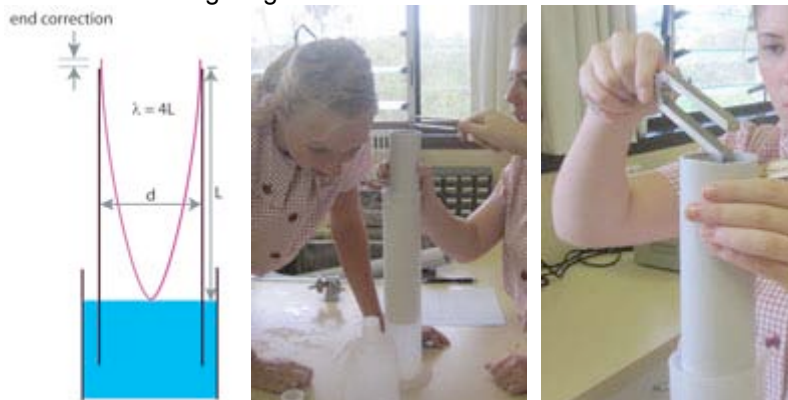

- **Speed of sound - is "end correction" really that correct?**

Following on from the description above - just how correct is the end correction formula: $e = 0.4d$? The end correction is the amount of length you have to add to the value for the length of the air column to get a correct value for the speed of sound. It is like a "fudge" factor but can be justified by physics theory. It would be interesting to see how accurate this factor is. For the first harmonic $\lambda = 4(L + 0.4d)$; for the next harmonic, the third harmonic (remember only odd harmonics with a closed pipe) $\lambda = 4/3 (L + 0.4d)$. If $v = f\lambda$ and v and f are constant then the velocity for the 1st and 3rd harmonics should be equal. You can solve for "end correction". What of the 5th and 7th harmonics; and does it vary with temperature, diameter of pipe and so on. This would be a great EEI that you could do at home or in the bush.

- **Time dependence of static friction**

This is going to be a tricky one and I haven't seen it done in a high school lab before. The research question posed is: how does static friction vary with contact time? That is, if you leave a block of wood sitting on a bench, is static (not dynamic) friction greater the longer you leave it? This is important in industry where detailed knowledge about static friction materials is required for the accurate calculation of the braking torque needed to hold a load at rest. This is particularly important for brakes in cranes, elevators, hoists and mining winding machines, which must meet specifications such as the definite value of the static safe braking factor. The study of static friction is also a useful supplement to the dynamic testing of brake friction materials. The time-dependence of static friction can be explained by the fact that the real contact area is a function of time. The (weight) force on the surfaces in contact gives rise to plastic deformation and causes the material to creep. Perhaps you could get some similar objects (steel, aluminium or wooden blocks and leave them on a surface for different times and measure static friction). Perhaps an incline method would be more accurate (measure height rather than angle). I've attached an interesting article by S.F. Scieszka and A. Jankowski (Poland) from the [Tribotest Journal V3\(2\) 1996](#) where they show that the coefficient friction is time dependent (by up to a maximum of 7-15%): $\mu_s = \mu_o + c_1 t / (c_2 + t)$, where c_1 and c_2 are constants. If you wanted to do it with low cost materials, I looked at using pine paddlepop sticks and chopping one into bits and letting a piece slide down. Glued two bits together

for a heavier object, then three. Hmm, not happy! This could be a truly great EEI.



Brakes on a gantry crane

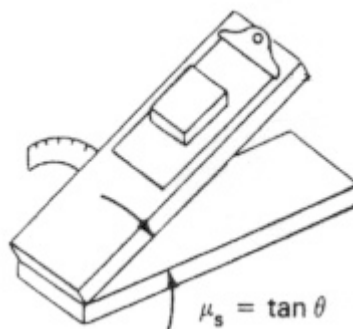

- **Rolling ball down an incline**

I once watched my own children roll a ball down an incline and as the incline angle was increased the ball sped up. However, there came a point when it got slower even as the incline was made steeper. That made me think it would be a great EEI as it was a bit unexpected. Obviously when the angle is 90° it won't go far - but what happens at smaller angles. A good research question is "for what angle will the horizontal speed be the fastest?" or if you are measuring the time to travel across a table (see diagram below) "for what time of travel across the tabletop be the least"? An interesting discussion by Physicist Mark Lattery from the University of Wisconsin USA appeared in [Physics Education \(V35\(2\) March 2000, 130-131](#). (click to download). You really need to look at changing another variable to look for interrelationships in the data (size of ball, balls of differing restitution) as this is a key criterion for an "A" in IP3. This will be so much fun.

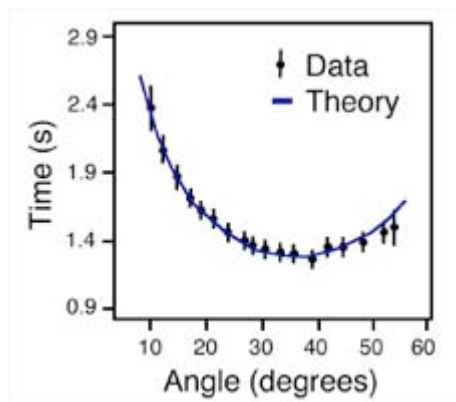
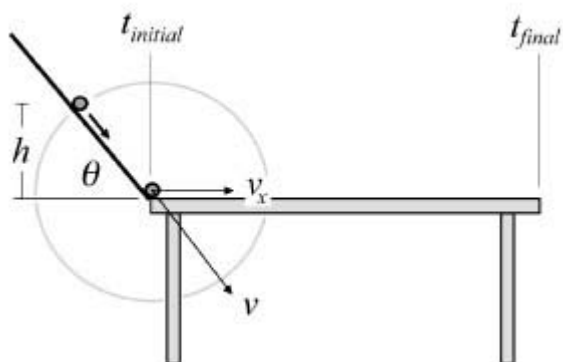

- **Bifilar pendulum**

A bifilar suspension pendulum is one in which two (bi) filaments (filar) support a rod. A schematic of this arrangement is shown in the figure below. Bifilar pendulums have been used to record the irregular rotation of the earth as well as to detect earthquakes. If a magnet is used instead of the rod, the rate of oscillating can be used to measure magnetic field strength. If a plain metal bar is suspended symmetrically in the horizontal plane by two strings of equal length and set to swing about a vertical axis through its centre, the period of the swing (T) may depend upon some, or all of the following quantities that define the system: the length of the supporting strings L ; the distance apart of the strings, s ; the mass of the suspended bar, m ; and the length of the suspended bar, l . There is a formula: $T = Ks^m L^n$ in which K is a constant and m and n are unknown indices. Thus: $\log T = \log K + m \log s + n \log L$. So if you do one experiment where L is kept constant and T measured for various values of s , then a graph of $\log T$ vs \log

s has a slope equal to m; and similarly, for another experiment you could measure T for various values of keeping constant and then you could graph log T against log L and this will have a slope of!
 What a fabulous EEI.

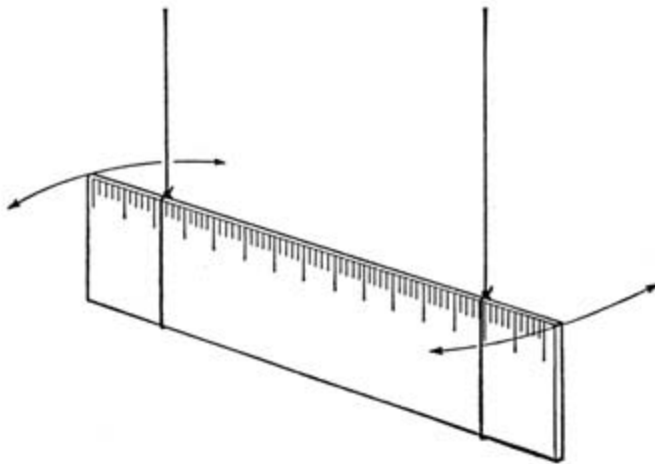

- **Torsion pendulum**

A torsion pendulum consists of a weight suspended by a wire or some other fibre. The pendulum oscillates by repeatedly twisting and untwisting about the axis through the centre of the wire. Though it is not strictly a pendulum since it does not oscillate because of the force of gravity, the mathematical formulas that describe the motion of a torsion pendulum are similar to the equations that describe the simple harmonic motion of a simple pendulum. It is commonly used in those ornate clocks in glass cases (see below). For a bob of fixed moment of inertia and a wire of a given material, the period (T) depends only on the radius and length of the wire: $T = Kr^a L^b$ where K is a constant, r = radius of the wire, L = length of the wire. Hence, $\log T = \log K + a \log r + b \log L$. Hence, if you use several identical wires (of the same type and radius) but different lengths, then a graph of log T vs log L should be a straight line of slope b.

Also, if just the radius is changed then a graph of $\log T$ vsetc. Another great EEI in the making.

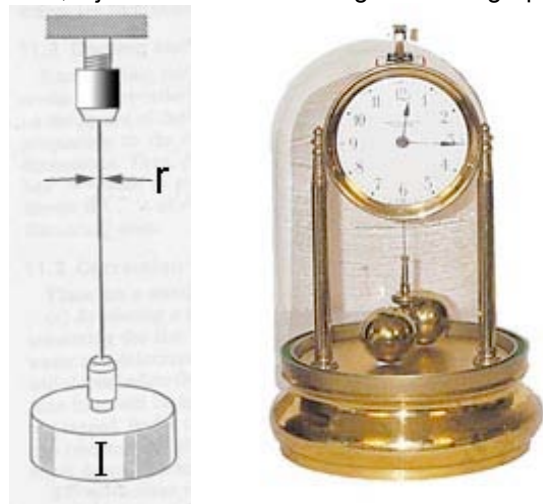

- **Cooking Meat I - Conductivity**

Food technology is a massive industry and physics principles can be applied to all facets. Physicist Dr Nathan Myhrvold worked alongside astrophysicist Stephen Hawking before turning his attention to cooking. He has recently released a 2438 page text on the science of cooking [*Modernist Cuisine*, Ingram Publishers, 2011, \$625). He said most people think that if a steak is twice as thick it should take twice as long to cook it to the same degree. However, he says that this is wrong and that heat conduction scales roughly as the square of the thickness so it should take four times as long. This would make a fascinating EEI. You would need pieces of similar meat but cut to different thicknesses. Different cuts of meat have different conductivity, with lean meat (low fat) having a higher thermal conductivity than fatty meat. The fibre direction also is important so there's a hint for a control. Government agencies define "cooked" as 70°C for 2 minutes (so does *Mythbusters*) so your best bet would be to see how long it takes for the temperature at the chosen positions (eg 1 cm and 2 cm) to rise to that value. It is also said that older animals have lots of connective tissue so "young" vs "old" may be interesting as another (discrete) variable. All you need is a lab hotplate and perhaps a few temperature probes and a datalogger.

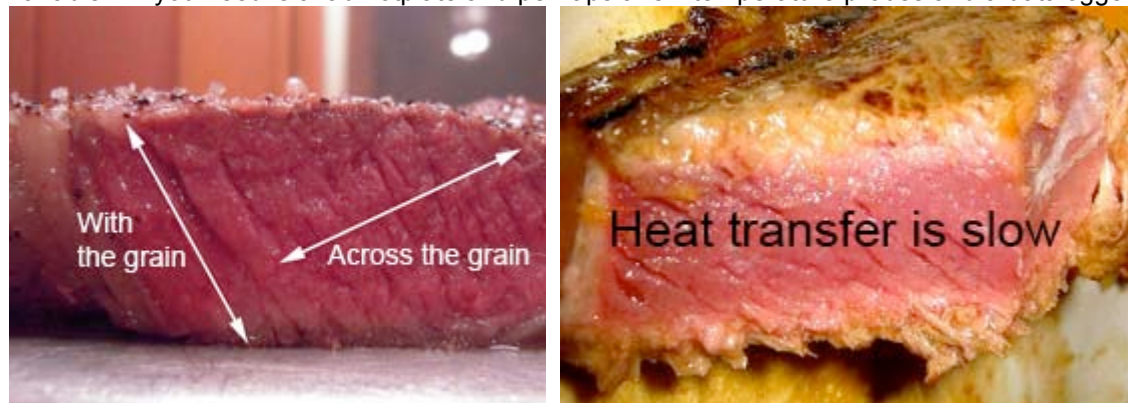

- **Cooking Meat II - Conductivity and Different Heat Sources**

The suggestion above describes the use of a hotplate as the heat source. A variation on that which would also make a good EEI would be to compare different heat sources. You could still use chunks of meat as above and still measure temperatures at say 1cm and 2 cm from the surface, and note how long it takes to get to say 70°C ; but compare the hotplate with a microwave and convection oven. You'd need to have some sort of measure of the heat output of the various devices on the setting used - perhaps putting a

known mass of water in a small beaker and heating that first (and use $Q = mc\Delta T$) and note the time taken to get a power ($P = W/t$) value. My thanks to Physics teacher and gastronome David Austin of North Bundaberg State High for his suggestion.

Cooking Meat III - Specific Heat

Similar to the experiment mentioned above, you could also make a good EEI out of investigating specific heats of various types of meat. The specific heat will determine how fast a piece of meat cooks. Lean meat is said to be the lowest specific heat at about 0.85 kJ/kg/K whereas fatty meat is about 0.95 kJ/kg/K. Bone is much lower at about 0.60 kJ/kg/K but this depends on how dense the bone is. You may need to develop a method based on ones you may have used for measuring the specific heat of brass, or look at the procedures used in food technology laboratories. I would look at heating a chunk to say 100°C in a laboratory oven and then dropping it in to chilled water (why chilled?). The problem you'll have is developing an hypothesis and justifying it. It is not much good for an EEI just to measure specific heats and leave it at that. You should be trying to extend knowledge about factors that affect meat specific heats and why it may be important. Talk to your teacher and look at the criteria sheet in detail before you get too carried away. I'd be thinking there is some relationship with moisture content or fat content. You could weigh a chunk of meat and dry it out for many hours in an oven, and then reweigh it to get % moisture. To measure % fat, you could extract the fat with hexane or some other non-polar solvent, and then evaporate the solvent. Plenty of methods are on the internet.

• Hot Air Balloons

Physics teacher at Urangan State High School, Hervey Bay, Queensland - Alan Whyborn - has his students investigate hot air balloons and the conditions needed for the balloons to catch fire. He said that he once saw a colleague in Canberra make hot air balloons from shopping bags, using metho and cotton wool, simply wired across the handles of the bag. They took them outside (on a still day), lit the metho and off they flew. On a number of the bags the opening collapsed in a little and the bags caught alight. He was horrified at the sight of flaming balloons releasing drips of burning plastic as they drifted casually through the air! He says: "In August 2007 in Canada, a fire broke out in a hot air balloon. Two people were killed. Could it be that the air in such a balloon may become excessively hot and cause the material of the balloon (the "envelope") to ignite and burn?" This sounds like the basis for an EEI: factors influencing the ascent of a hot air balloon. Alan gives the following important tips: large, really thin/light garbage bags must be used, and get the lightest cane available (craft shop). Also, if the balloons are allowed to fly to the ceiling, they can tilt and the bag might catch fire, so the anchor is very important (plus it holds the balloon in place while the pebbles are added to the gondola to increase the payload). Also, still air is necessary - inside the lab with fans off is great. If done carefully with appropriate preparation and warnings, there is very little hazard. In some cases, students have had a "fuel load" big enough to create sufficient heat to shrink the bag. Ordinary cotton wool balls are perfect, but not compressed or the rate of heat release might not be sufficient to get necessary lift. Click here for: [Procedures and safety notes from Urangan SHS.](#)



Constructing: a light cane loop and sticky tape holds the bag end open. Fine wire across the middle is used to attach the fuel ball and gondola.

Fuelling: a cotton ball soaked in metho is attached by a hook to the centre wire.

Inflating: the ball is lit and the bag fills. A slack safety cord tethers the bag to the floor.

Loading: pebbles are added to the gondola to achieve neutral buoyancy.

- **Slump of sandpile**

You've no doubt seen reports on TV of kids being buried on the beach when a sandhill collapses on them. The sand is stable until someone digs away at the base. When bulk granular materials (like sand) are poured onto a horizontal surface, a conical pile will form. The internal angle between the surface of the pile and the horizontal surface is known as the *angle of repose* and is related to the density, surface area and shapes of the particles, and the coefficient of friction of the material. Material with a low angle of repose forms flatter piles than material with a high angle of repose. The angle of repose, or more precisely the critical angle of repose is the steepest angle of descent or dip of the slope relative to the horizontal plane when material on the slope face is on the verge of sliding. Likewise, the larvae of the antlions trap small insects such as ants by digging conical pits in loose sand, such that the slope of the walls is effectively at the critical angle of repose for the sand. When the ant walks on the sand it collapses and he falls in to the hole. Now that's clever. A great EEI would be to measure the angle of repose for different grain sizes of sand, or wet vs dry sand, or if it is related to density and so on. Look up the *triaxial shear test*, or even the *direct shear test* for ideas on how to measure repose.



Angle of repose is measured in degrees



Antlion sand trap

- **Insulation and cooling of hot water**

Bubble wrap is a good insulator but how would the rate of cooling of a PET water bottle of hot water vary with the number of layers of wrap? Newton's law of cooling makes reference to the rate of cooling and the difference in temperature between the object and room temperature (but he also said 'in a gentle breeze' that most Physics books forget to mention. Perhaps the initial temperature is important, or perhaps the volume. Can you estimate what fraction of a layer of bubblewrap the polyester (PET) bottle is equivalent to? Maybe compare it to metal or glass.



- **Home Made Accelerometer**

Accelerometers are devices for measuring the net acceleration force acting on an object. In the computing world, IBM and Apple have recently started using accelerometers in their laptops to protect hard drives from damage. If you accidentally drop the laptop, the accelerometer detects the sudden freefall, and switches the hard drive off so the heads don't crash on the platters. In a similar fashion, high g accelerometers are the industry standard way of detecting car crashes and deploying airbags at just the right time. Apple uses an LIS302DL accelerometer in the iPhone, iPod Touch and the 4th & 5th generation iPod Nano allowing the device to know when it is tilted on its side. These are all pretty complicated but you could build a simple one from a narrow perspex or glass tank partly filled with a water and food colouring and mounted on top of a collision trolley. There is probably a relationship between the angle of the water surface and the amount of acceleration. I suspect you'll need a camera - maybe an SLR unless your compact has low shutter lag. Better still, mount your accelerometer on a spinning

turntable and you'll be delighted for hours.

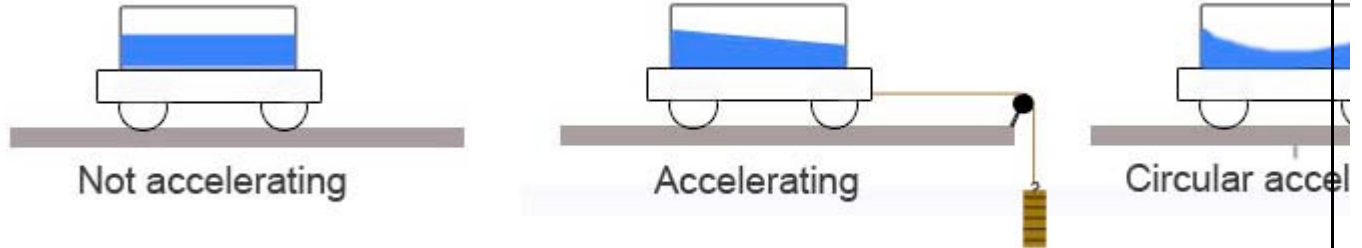

- **Photonics and fibre optics**

The Australian Government's National Broadband Network is planned to connect 90% of all Australian homes, schools and workplaces with broadband services using fibre optic cable. Understanding the physics behind fibre optic technology is set to become even more important to those involved. As signals pass along the fibre they get weaker (attenuate) as the light gets absorbed and scattered on its way through. Attenuation is one of the most important measurements for optical transmission systems because it determines the maximum distance between repeaters. With new glass that has been developed for optical fibres, light can travel more than 10 km before 90 per cent of it is absorbed. This is a big improvement over ordinary glass which loses 90% in 20 metres. Some interesting experiments involve modelling optic fibre with glass rod (eg stirring rod) and making different bends in a number of pieces. Compare energy losses ("curvature loss" or "macrobend loss") as a function of angle. Try dipping the rod in different liquids (to simulate the cladding) and measure the attenuation again. Try different thicknesses of rod. Put scratches on the glass. I'm tld that if the radius of the bend is greater than 20 times the diameter of the fibre, then losses are negligible. Hmmm!

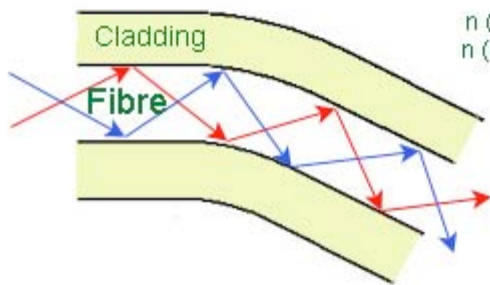

Shallow bend

$n(\text{cladding}) = 1.42$
 $n(\text{core fibre}) = 1.55$

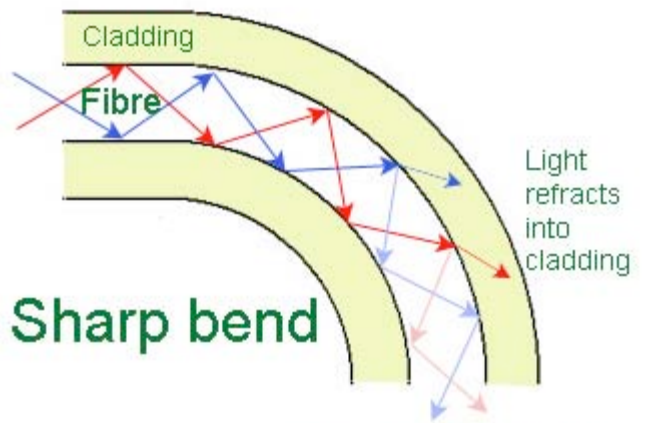

Sharp bend

Bicycle Pump Thermodynamics

You are probably well aware that when you compress air quickly in a bicycle pump the pump gets hot quickly. The energy imparted by your muscles is transferred into heating the gas inside the pump and increasing the molecules' internal energy. This is the same reason spacecraft get hot when they re-enter the Earth's atmosphere - adiabatic compression (not friction). Diesel engines rely on adiabatic heating during their compression stroke to elevate the temperature sufficiently to ignite the fuel. If you had access to a temperature probe and a datalogger you could mount the probe into a screw fitting and screw it into the end of a pump. Let some masses compress the gas and take a few readings. It's up to you what data to take and how to work out how much mechanical energy is imparted to the gas by the falling masses. Is it okay to assume that there is such little time for heat to escape to the surroundings that $Q(\text{lost}) = 0$? Will

the formula $W = Fs$ be okay? *Wikipedia* has done a lot of the hard work for you.

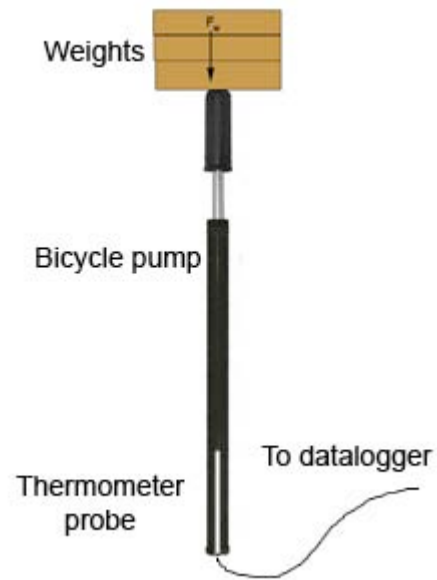
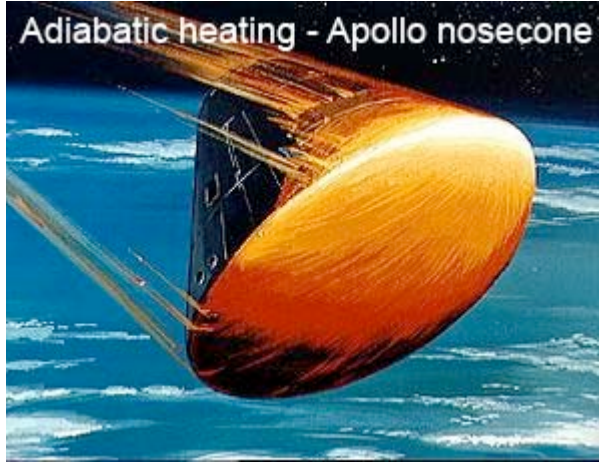

- **The Stud Finder**

The stud finder is a device designed to indicate the presence of wood studs behind wallboard by detecting changes in capacitance. Generally, each detector contains a capacitor whose conductive plates are arranged so that both plates lie in the same vertical plane (see figure below). When the device is placed in contact with a wall, that plane is parallel to the wall, causing electric fields generated by the pair of plates to penetrate behind the wallboard. As the detector is moved across the wall, those fields are affected by what dielectric material is present, resulting ultimately in changes in capacitance. Those variations are detected and then indicated by changes in light and/or sound intensities. For the stud sensor, the presence of a wood stud behind the wallboard causes the capacitance to increase in that region due to an increase in dielectric constant. For an EEI you could investigate the properties of a commercial studfinder (about \$25): do different wood types have different capacitance; effect of moisture content of the stud; metal vs wood; electrical cables (on and off); effect of thickness and so on. Perhaps you could make a model one and compare.

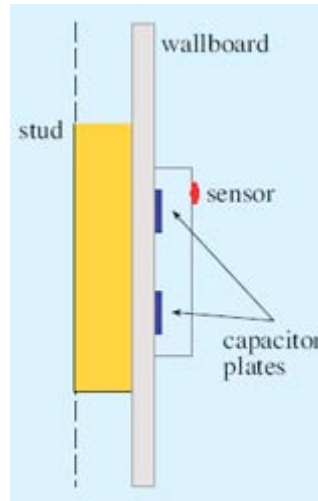

- **Magnetic Strength and Distance**

In World War 2, the Navy in Australia, Britain and the United States received tens of thousands of

suggestions about how to detect enemy submarines. Most involved placing big magnets in the shipping channels. These were rejected by scientists as being impractical because they knew magnetic strength falls off alarmingly with distance. However, it may not be a simple inverse square law as that really only applies to isolated magnetic poles. When you have the real world of dipoles (N and S on the one object) the relationship is less clear. So, for an EEI you could investigate force vs distance for a pair of magnets. The diagram below may give you some ideas. But is the "dipole" a problem. If you had really long magnets then the second pole on each magnet may not be as important. That is, is length of the magnet a variable?

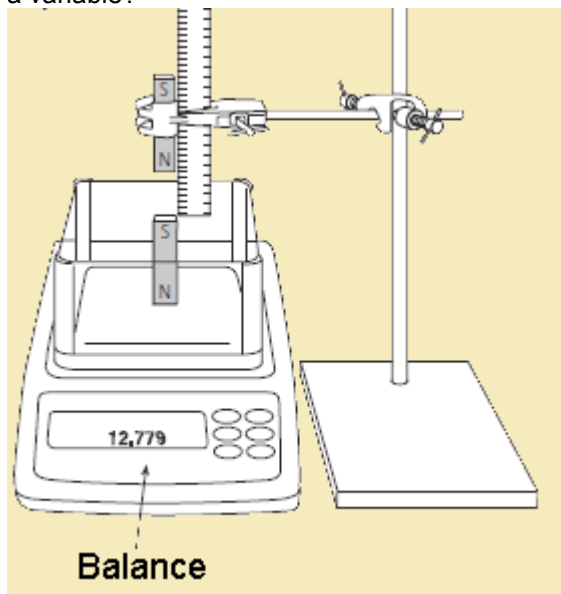

- **Force between two current-carrying wires.**

If you've ever watched someone try to "jump start" a car with a flat battery you may notice something funny happen to the wires. "Jumper leads" are two heavy duty copper wires that are connected between the good battery on one car to the flat battery on the second car. Positive is connected to positive, and negative to negative. When current is drawn through them by the flat battery trying to start, the leads move towards each other (if they are close enough). Ampere devised a formula relating the length of the wires and the currents being carried. You could test this in an EEI but the formula may hold for an ideal case of very long (infinitely long?) wires. How does it hold as the wires are varied in length. That is, are there any "end effects"? And should the force be zero when they are at right angles (the textbook say "yes"). Here's a suggestion: use an electronic balance, hold a stiff wire (rod) in a clamp and blu-tac the other rod to the balance pan (see below). Solder (clip) lightweight flexible wires to the ends and connect to power supply (full-wave rectified?) and appropriate meters. Bob's your uncle.



- **Newton's Cradle and non-elastic collisions**

Newton's cradle, named after Sir Isaac Newton, is a device that demonstrates conservation of momentum and energy. It has no real-world application other than as a toy. A typical Newton's cradle has a series of identically sized metal balls suspended in a metal frame so that they are just touching each other at rest. Each ball is attached to the frame by two wires of equal length angled away from each other. This restricts the pendulums' movements to the same plane. There are plenty of videos and demos on the internet if you have not seen one live. They work well for steel balls; but what about brass, what about lead. Is there a relationship between starting height and final height when less elastic metals are used. It's no good just finding out there is a difference without having some hypothesis to test. Is it a density thing, or interatomic force thing? There must be some quantitative difference between the metals that gives rise

to observed differences in the balls' behaviour. This will be hard.



- **Heating up gases**

You would have seen how gases expand when they are heated. Your teacher may have heated a flask with a balloon on the top to show it expanding; you may have seen a balloon shrink when dipped in liquid nitrogen at -198°C ; and it is the principle behind how hot air balloons work. In class you would have called the law describing the relationship between temperature and volume Charles's Law or perhaps Amonton's Law ($V \propto T$, when T is in kelvin and P and n are kept constant). There could be a great EEI in revisiting this relationship. There is no point in just verifying it as this has been done a million times. What you want to do is to extend the investigation of this law to look at the impact of changing variables and to consider allowing for errors. The diagram below shows a setup that may be useful. It really just show the connection of two things: a flask with a sidearm (maybe a Büchner flask) and a graduated glass syringe. The exact positioning is something you should determine. Glass syringes are precision-made with low friction between the plunger and the barrel (unlike plastic ones that have high friction). Your chem lab should have some and if not they are reasonably cheap (about \$50 for a 100 mL one). You need to introduce a gas (eg CO_2) into the flask and surround the flask with water in a beaker on a hotplate. As it slowly heats (I mean slowly, maybe 20°C to 80°C over 40 minutes) the gas expands and the syringe is pushed out. With the syringe on it's side there is no need to worry about the weight of the plunger. You could compare gases - oxygen, nitrogen, hydrogen for example. But how to get samples of these gases? You may have cylinders but you could produce H_2 and CO_2 by reaction (or let some dry ice sublimate); let some liquid nitrogen evaporate (or remove oxygen from air). And why not propane (BBQ gas) or butane (cigarette lighter fluid)? Remember that balloon gas is not just helium - it has 3% air mixed in with it. The main point is that the law holds for ideal gases but at atmospheric pressure and room temperature they won't be that ideal. And is the deviation from ideality dependent on the molar mass of the gas, or whether it is polar or non-polar, and where on earth do you get a polar gas from (HCl is too dangerous)? What range of temperatures will you use (consider liquid nitrogen, dry ice). What value will they give you for absolute zero when the V/T graph is extrapolated? How do you draw the line of best fit (is least-squares the best, does it give you the most accurate value for absolute zero?). And what is the volume of the gas in the apparatus? And what is the best way to measure temperature (of the gas as in the diagram, or of the water surrounding it)? Perhaps the temperature of the gas in the flask is the water temperature and the temperature of the gas in the syringe that of the surrounding air (work out a weighted average). And how do you control atmospheric pressure (do you have a barometer, or perhaps get the data from the meteorological bureau website). What a fabulous EEI. I must put this on the [Chemistry EEI webpage](#) as well.



Charles's Law

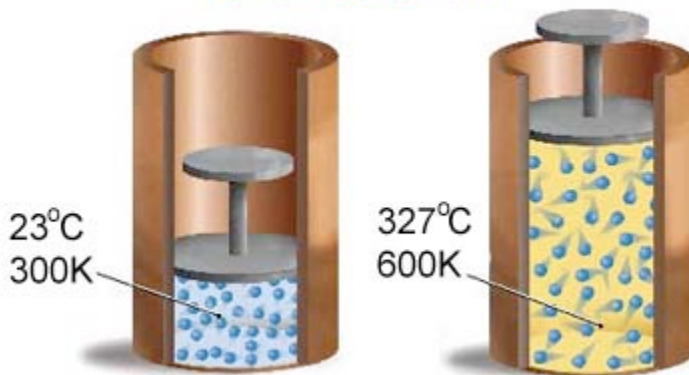

The Heat Engine

You are probably quite familiar with things physicists and engineers call "Heat Engines": the petrol and diesel engines for cars and trucks are heat engines as they convert heat energy to mechanical work by exploiting the temperature gradient between a hot "source" and a cold "sink". The diagram below left shows this process schematically. Heat is transferred from the **source** (T_{hot}) through the "**working body**" of the engine, to the **sink** (T_{cold}), and in this process some of the heat is converted into **work** (W) by exploiting the properties of a working substance (usually a gas or liquid). Even a "Dunking Bird" is a heat engine (centre). This suggests a good EEI based on an experiment often done in thermodynamics labs in 1st year university physics or engineering. The diagram to the right shows the setup. It consists of a flask connected to a glass syringe (see description in the "Heating up Gases" suggestion above. The heat engine works when the flask is shifted by hand from the cold water to the hot water and back again. The pressure of the system is monitored with the pressure sensor (to computer) and the volume of the system can be measured with the rotary motion sensor on the piston. You start with the flask in ice water and no mass on the piston. Then place a mass on the piston and the plunger falls. Then transfer the flask to the hot water and the piston rises. When it stops rising you remove the mass and then move the flask back to the cold water. That is one cycle. Some data I have from the *American Journal of Physics* (V 74 (2) Feb 2006, p 99) has $T_{\text{hot}} = 90^{\circ}\text{C}$, $T_{\text{cold}} = 25^{\circ}\text{C}$, mass added to piston = 100 g, height lifted = 2.7 cm). With the right formula you get a value for W_{in} (heat) = 29 mJ, and W_{out} (GPE) of 26 mJ giving a mechanical efficiency of 90%. Ask yourself - what is the source of energy loss? For an EEI you would need to

research these formulas and the underlying theory and propose some variables to manipulate such as ΔT , mass, type of gas and so on. Whatever you choose you should have some way of justifying your hypothesis. Hard, but may be fun.

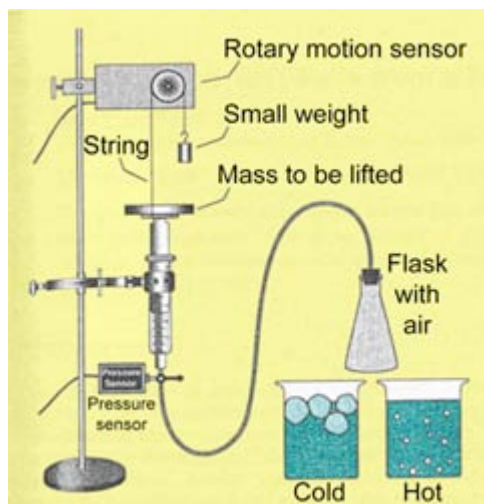
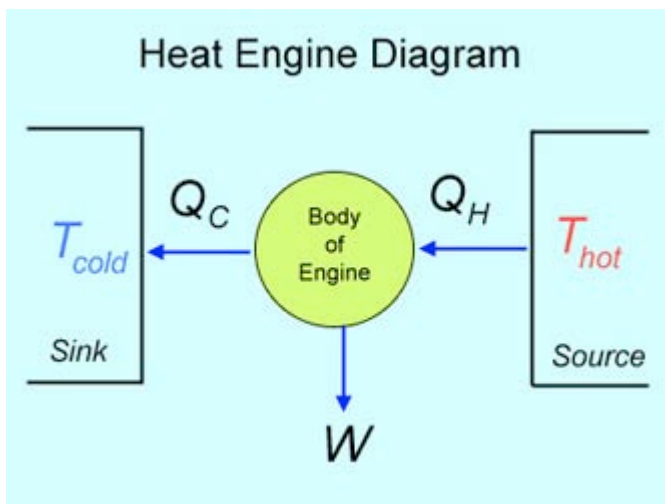

- **Datalogging Power Generation**

The fundamental principles of electricity generation were discovered during the early 1830s by the British scientist Michael Faraday. His basic method is still used today: electricity is generated by the movement of a loop of wire near a magnet (or vice versa). You could do an EEI on the factors influencing the generation of an electric current. A good way would be to use a Pasco (or similar) datalogger and record the voltage induced in a coil (air solenoid) by a spinning magnet nearby (see photo). The experiment could be repeated with the spinning magnet closer to the coil, or the number of turns on the coil can be increased or decreased. These variations will cause the area for a half-cycle to change, but again this can be shown to be independent of speed. If the number of turns on the coil is changed by a known ratio, the area for a half-cycle should change by the same ratio. You could also set up three coils at 120° to each other. Photos courtesy of Mark Dixon, Clifton College, Bristol, UK.

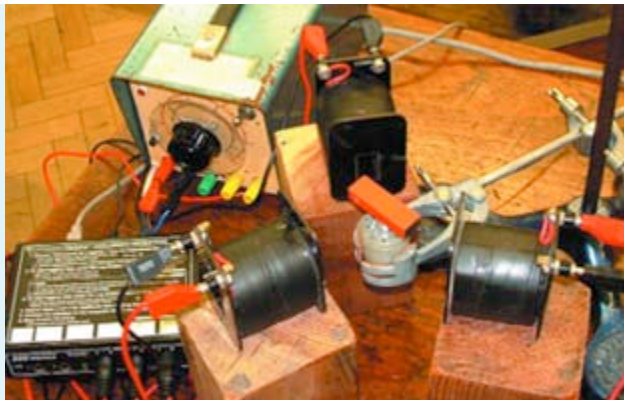
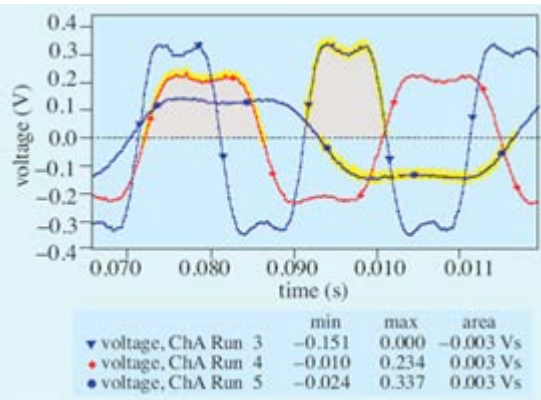

● **The Physics of the Bungee Jump**

National Geographic magazine first reported this sort of jump by Pentacost Island natives in 1955. It was later popularised by A. J. Hackett in NZ. The conversion from GPE to EPE is an interesting one but the relationship is far from simple. You could model a bungee using rubber bands and brass weights, or do something more dramatic. You may even find out why they say bungee jumping is glue sniffing for Yuppies. One of the problems is that as the jumper falls the mass of rope hanging below is getting less so acceleration is actually greater than g . That sounds wrong but it appears to be true. Have a look at: [Understanding the Physics of Bungee Jumping](#) from *Physics Education* V45(1) 63-72 (January 2010) and you'll see what I mean.

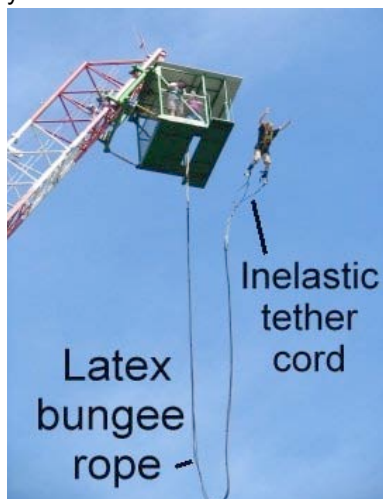

- **What type of waterwheel is the most efficient?**

A water wheel is a machine for converting the energy of flowing or falling water into more useful forms of power, a process otherwise known as hydropower. In the Middle Ages, waterwheels were used as tools to power factories throughout different counties. The alternatives were the windmill and human and animal power. Overshot (and particularly backshot) wheels are said to be the most efficient types; with claims that a breastshot steel wheel can be up to 60% efficient (but who'd believe Wikipedia?). Why not make this the subject of an EEI and see if efficiency depends on fall height, rate of flow, paddle area and so on? Great fun if you're good at constructing things. But be warned - it's no good just making a couple and testing them; you need to vary some of the parameters and hypothesise how this may affect efficiency.

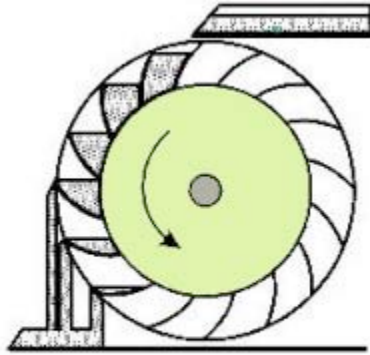

Overshot

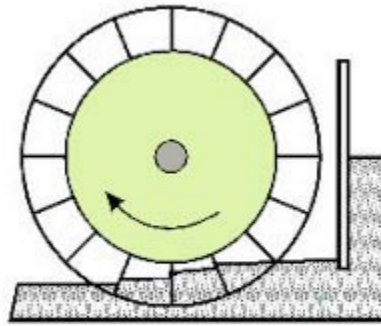

Undershot

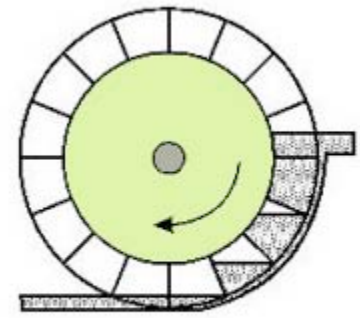

Breastshot

- **Flight of a Golf Ball**

This was first investigated by Prof. Peter Tait of Edinburgh University in 1900. His son was Scottish National Golf Champion who could hit a ball further than the mechanics formulas of the time predicted because they didn't know about spin. It still makes a great EEI as there are so many things to investigate. Try: angle vs. number of dimples; try sanding off one-quarter of them and putting gloss paint to make it smooth again; then try half (see below), and three-quarters. Design a device for giving it a constant velocity, eg falling pendulum, or something spring-loaded. Vary angle, try at different speeds. How to get top spin?

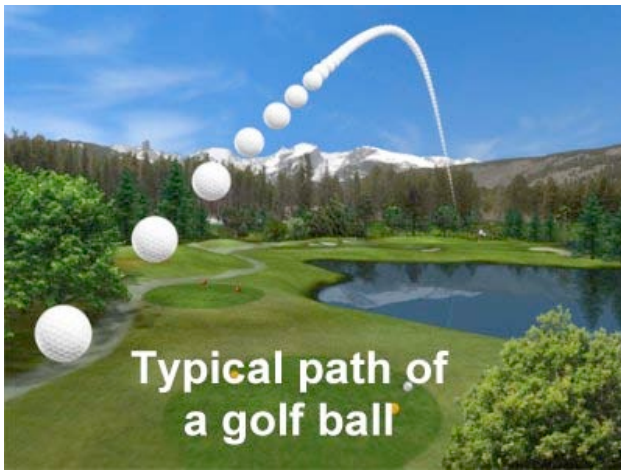

- **Gravity car**

An old favourite for physics and engineering competitions is the 'gravity car'. It involves the transfer of gravitational potential energy from a falling weight to an attached small model car which acquires kinetic energy. There are many designs but a simple one is shown below. The brass weights are attached to a string passing over a pulley attached to the car. The string is wound around the axle. As the weights fall and lose GPE, the string turns the wheels and the car begins to move. Your EEI could investigate the optimum falling mass and cart mass combination for maximum acceleration or velocity. Remember - as you increase the falling mass (and thus DGPE) you are increasing the mass of the whole system. This

will have implications for acceleration. A great EEI and lots of scope for demonstrating advanced thinking.

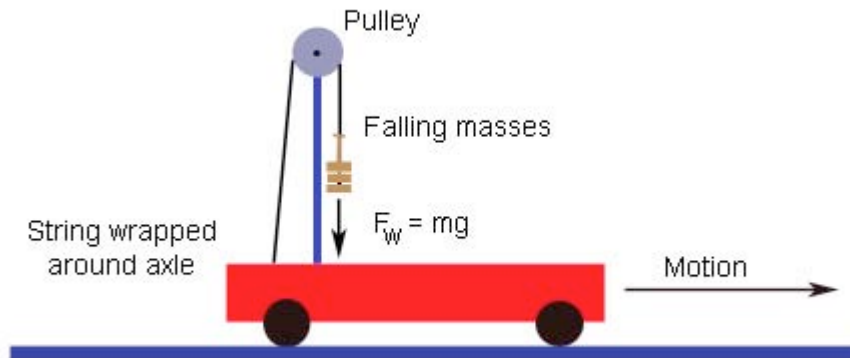

- **Descent of a ball bearing in oil**

It is vitally important that motor oil doesn't get too thin in summer nor too thick (too viscous) in winter otherwise the car engine might seize. A Falling Ball Viscometer uses the rate of descent of a ball bearing to measure the viscosity of a liquid. Try investigating drop time vs. temperature, type of oil (20W50 etc), size, mass or density of ball, width of column. This can be very messy; oil is such a pain to clean up you're probably used to having someone else clean up for you. So don't be surprised if your teacher seems reluctant. Perhaps try a golf ball in a measuring cylinder or water at different temperatures.

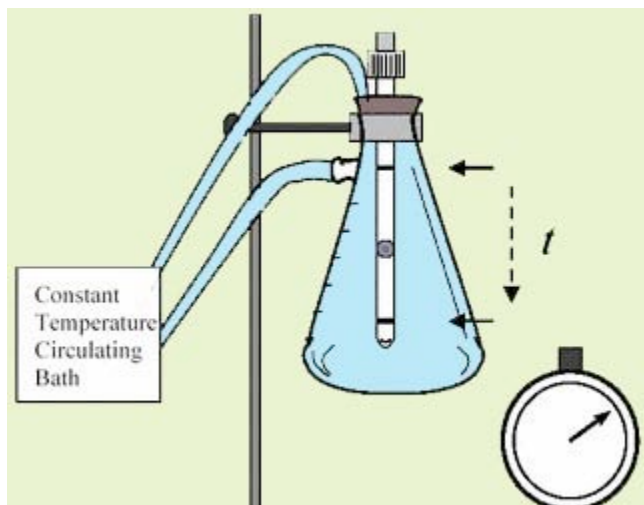

- **Air resistance and the descent of a balloon**

Inflated party balloons fall slowly to the ground because of their large cross-section for their weight (low density). Students often think a good EEI would be to investigate the effect of air resistance on falling objects (eg tennis, ping pong and cricket balls) but mostly the objects fall too fast and the measurement error is too great. A great EEI would be to suspend a motion sensor (ie a sonic ranger) from the ceiling and let an inflated balloon fall from underneath it. You could increase the mass (add paperclips etc) and redo the measurements keeping diameter constant. Then you could keep the mass constant and change the (you work it out!). The main things to look for are large lightweight objects such as plastic soccer balls, inflatable beach balls, styrofoam balls (eg the round foam fishing floats in the photo below). Small weights can be taped on the bottom or pushed into the foam; and you may need quite a large fall height. Remember that air resistance is not constant as a dropped object accelerates - it increases with velocity (squared). And that why this is a tricky (but great) investigation for an EEI.

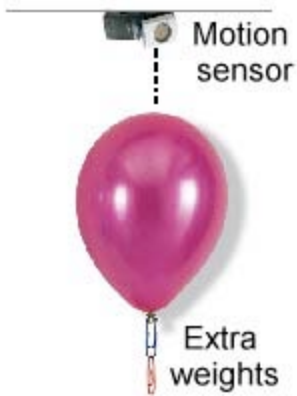

Stability of a bicycle

Have you noticed how you can ride a bike with your hands off the handlebars and you don't fall over? But if you give it a push just how long does it take to fall over? Variables - linear speed, mass, angular speed of wheel, rotational inertia of wheel $I = mr^2$; add lumps of clay or lead to rim).

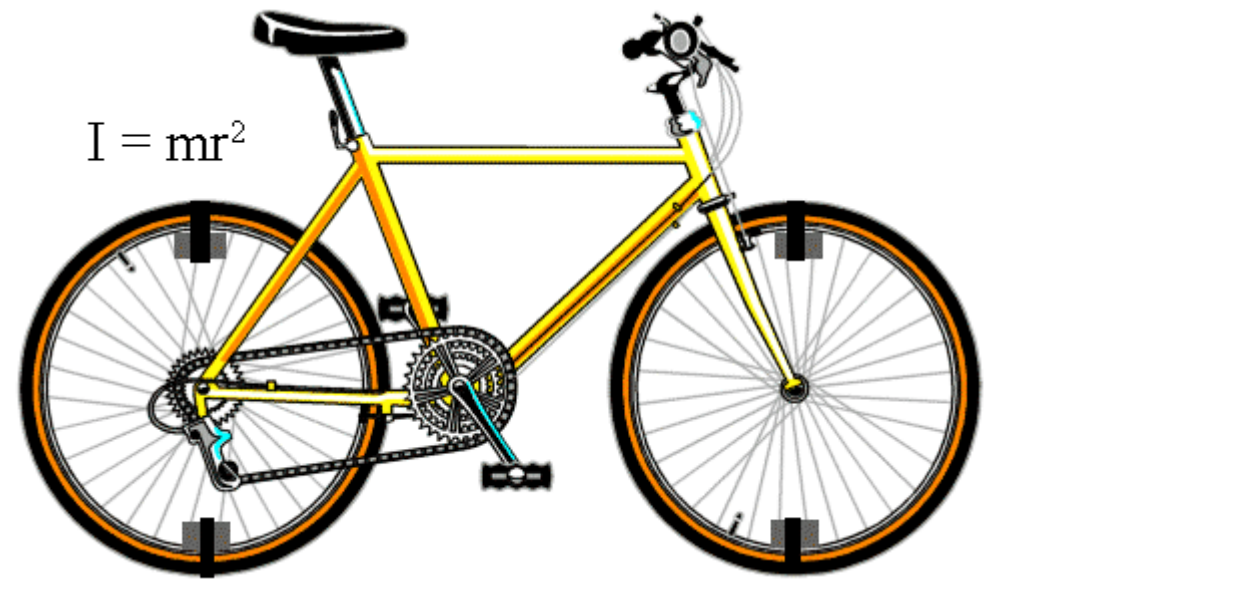

- **Sliding friction - variation with speed?**

You've no doubt measured the coefficient of friction by pulling a wooden block across various surfaces at constant speed and measuring the force with a spring balance. Probably you've found that friction is independent of surface area and normal reaction force (laws of da Vinci, Amonton and Coulomb). That's fine but you might recall how difficult it is to get constant speed. The problem is that friction does change with speed (particularly for dry, unlubricated metals) although it may be not noticeable. For steel, copper and lead, the frictional force seems to decrease with speed; with Teflon it increases with speed; and in many cases complicated relationships exist: for example, for steel sliding on polymers such as polypropylene and butadiene acrylonitrile, a peak in the graph of friction versus speed is observed. A good EEI would be to extend this idea and measure the displacement or speed as a function of time as you add different weights and try different surfaces. Think about grouping the surfaces into elastically hard and elastically soft (rubber, textiles). Some computer interface packages have a "smart" pulley that gathers data. The diagrams below may give you some ideas. Perhaps a better way of measuring friction would be to measure the acceleration of the system and using Newton's 2nd law (where F_{net} is the calculated force accelerating the blocks and m is the total mass of the system (both objects)). The net force will be less than the applied force (the weight of the block) and the difference will be due to friction. A good paper for background reading is "How to teach friction: Experiments and models" by Besson, Borghi, Ambrosio and Mascheretti from the A.Volta Department of Physics, University of Pavia, Italy in the *American Journal of Physics*, December 2007, V 75, No. 12, pp 1106.

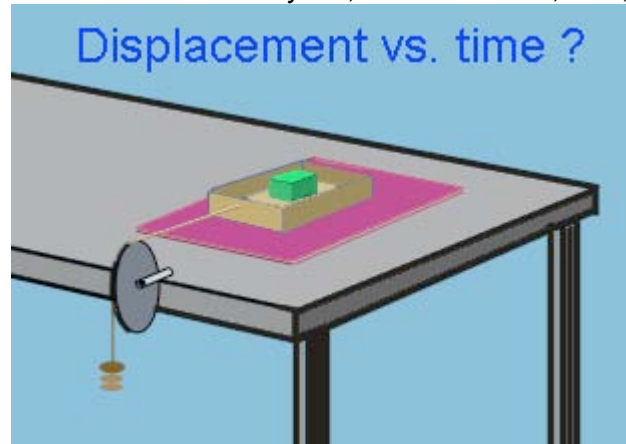

Pasco Smart Pulley



- **Pulling a nail out**

Use a claw hammer to pull a nail out of wood. See suggestion below. Need to compute mechanical advantage of lever. How does force (calculate $F_1r_1 = F_2r_2$) vary with depth of nail, diameter of nail, grain orientation (end, side, top), density of wood. How does a pre-drilled hole (varying diameter) help or hinder? *Scientific American* had an article in about 2007. They said the force to pull a 50mm nail out of

end-grain of seasoned hardwood was about 260N, but the force became lower as it came out. How would you measure the force as a function of distance embedded. Now that's difficult!!

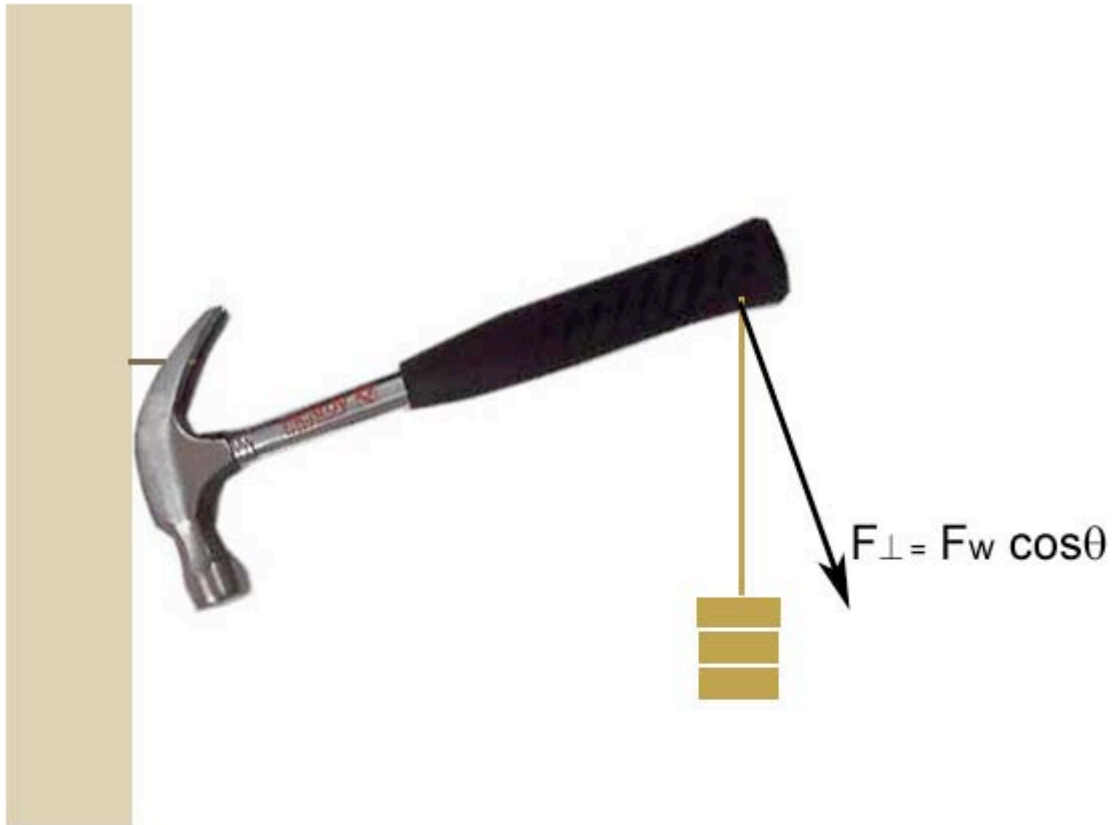

- **Cooling rates of ice in a freezer**

Some people say that warm water freezes before cool water but that seems to violate common sense and physics principles. You could investigate some factors: Rate vs. container size, thickness or type of material, covered/uncovered, initial temperature, stirred/unstirred. Good one for thermometer probes and a computer interface, eg TI-CBL2, Casio, Datamate etc.

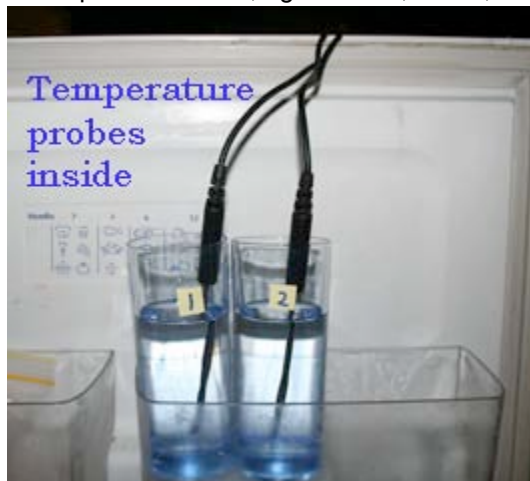

Chladni Plate investigation.

You may have seen demonstrations of Chladni Plates where a plate sprinkled with sand and attached to a vibrator is caused to vibrate and a series of patterns emerges depending on the frequency (see below). It has societal applications: in recent years, there has been increasing interest in the positioning of micro- and nano-particles on surfaces for the production of miniature biosensors and molecular electronics. Chladni processes can be used to do this instead of the slow and cumbersome lithography or prefabricated patterns (e.g., by electrostatic positioning). But even though they may be fun and look fascinating, as an EEI they can be quite hopeless - so be warned!! Usually students increase the frequency and note the value at which a stable patterns emerges and take a photo. This is not necessarily good EEI as there is nothing much to analyse; all you've done is redo a demonstration that has been done a million times over the past 220 years. However, you could also record the m and n values from the pattern (by inspection; see middle photo below) and then analyse the results to see if Chladni's Law is obeyed ($f \sim (m + 2n)^2$ which it probably won't be but the discussion can be all about the limitations. Perhaps comparing square plates of different thickness (but same area) maybe more fruitful; or perhaps square ones of same thickness but different areas. That way you'll be able to manipulate two continuous variables (frequency and length). Student (Brianna) from Wynnum State High made her Chladni plate vibrator from instructions at [Instructables](#).



Physics teacher Steve MacPherson at Wynnum State High School, Brisbane, demonstrating Chladni figures to a Year 10 Science class using a home-made setup.

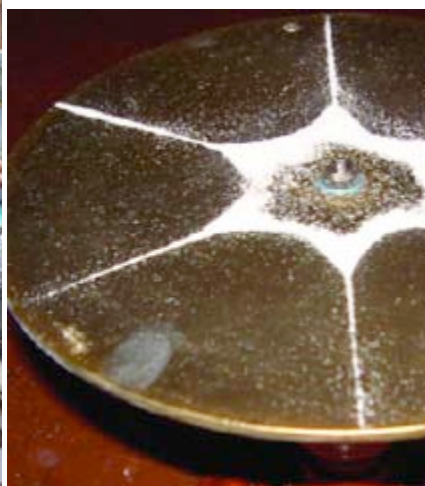

A simple Chladni pattern on a circular plate. Here the student has generated one with $n=3$ nodal lines and $m=0$ nodal circles.



A "Sinai Billiards" pattern (complex, chaotic) generated by Yr 11 Physics student (Brianna) at Wynnum SHS during her EEI.

• Loop the Loop - measuring "Jerk"

For an object travelling in a circle, its centripetal acceleration is given by $a_c = v^2/r$. If it is moving in a vertical circle, its speed may change from bottom to the top, so does its acceleration. The rate of change of acceleration is known as "jerk" - units: ms^{-3} . Examine the *jerk* of an object to model the motion of an aircraft in a loop-the-loop. By the way - railway engineers try to keep *jerk* below 2 ms^{-3} to avoid passenger discomfort.

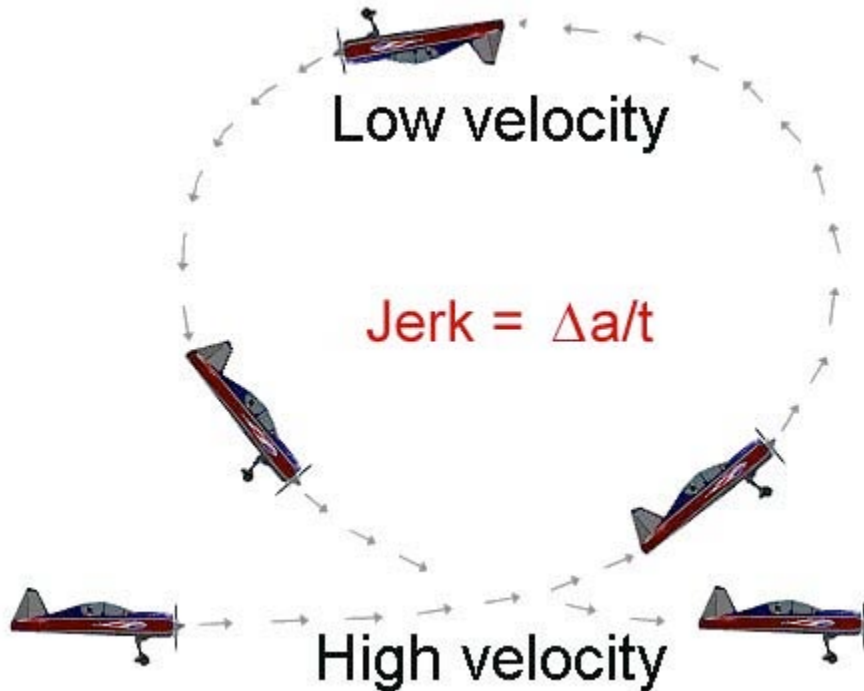

- **Effectiveness of sunscreens**

To limit the amount of exposure to harmful UV radiation, sunscreens are recommended. Suntan and sunblock lotions are two different products. Sun blocks contain compounds like titanium dioxide or zinc oxide that completely prevent all light from reaching the skin. Suntan lotions contain compounds that absorb UV radiation and reduce the amount of UV radiation that is absorbed by the skin. The ability of a sunscreen to protect the user from UV radiation is defined as the Sun Protection Factor (SPF). Some good EEIs have been done on looking at the effectiveness of sunscreens in blocking different wavelengths. It may be hard (and dangerous) to get a laboratory source of UV so you could do it with just the Sun. I've seen some done with light-sensitive paper to measure the sunlight getting through a thin

film. Yr 12 Physics student at St Patrick's College, Mackay, Queensland, used different SFP sunscreens smeared on Gladwrap.

- **Hot spots in a microwave oven**

Your aim could be one of either (or both): to measure experimentally the wavelength of microwaves in a microwave oven; and/or where are the hot spots and how do they correspond to antinodes based on the answer to the first question. Try investigating temperature rise vs. location; differences between horizontal and vertical planes; which materials should I use - butter, chocolate, water, grapes. The photo on the right below shows a visualization of the horizontal mode in a microwave oven using infrared thermal imaging. A glass plate with a thin water film was placed at a height of 8 cm and heated for 15 s with a microwave power of 800W without using the turntable. The antinodes are clearly visible. Source: Michael Vollmer (2004). Physics of the microwave oven. *Physics Education*, V39 (1), p 77.

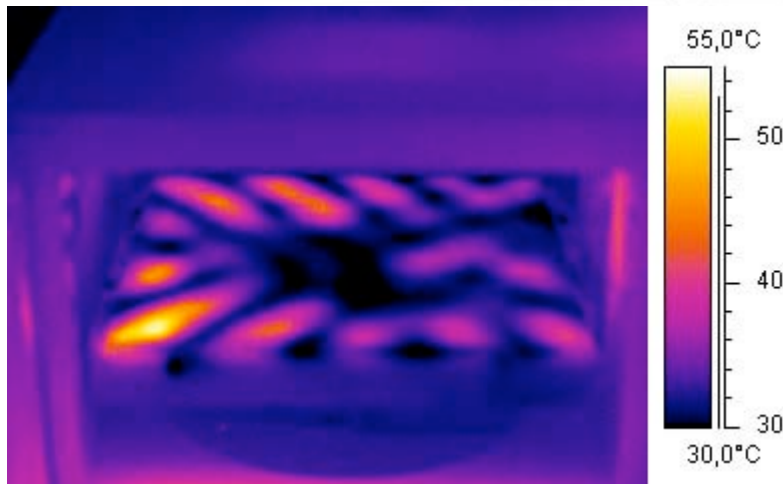
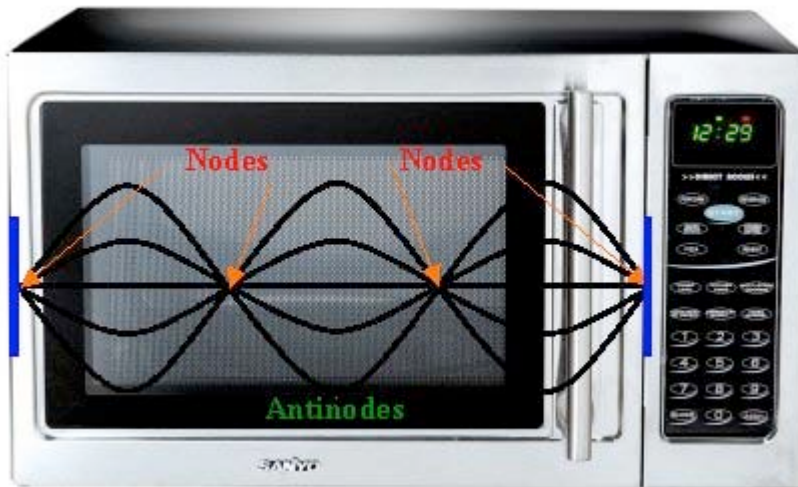

- **Beam Deflections**

Structures such as buildings and bridges consist of a number of components such as beams, columns and foundations all of which act together to ensure that the loadings that the structure carries is safely transmitted to the supporting ground below. Normally, the horizontal beams can be made from steel, timber or reinforced concrete and have a cross sectional shape that can be rectangular, T or I shape. The design of such beams can be complex but is essentially intended to ensure that the beam can safely carry the load it is intended to support. Planning to do engineering at uni next year? Then why not get a head start and do a "beam deflection" EEI? Here's the scenario: as a structural engineer you are part of a team working on the design of a prestigious new hotel complex in a developing city in the Middle East. It

has been decided that the building will be constructed using structural steelwork and, as the design engineer, you will carry out the complex calculations that will ensure that the architect's vision for this new development can be translated into a functional, economic and buildable structure. As part of these calculations you must assess the maximum deflections that will occur in the beams of the structure and ensure that they are not excessive. It is said that the deflection of a spring beam depends on its length, its cross-sectional shape, the material, where the deflecting force is applied, how the beam is supported and so on. But perhaps this is only true when you use homogenous, linearly elastic materials, and where the rotations of a beam are small. I'm not going to give you too many ideas! Have a look at Scott Boon's EEI photos below (Bundaberg North State High School, Queensland). He's an engineer in the making. My thanks to teacher Mr David Austin for his help.



The load was water in a bucket.



Laser pointer helped with accuracy.

- **Descent of golf balls down an incline**

If you roll a golf ball down an incline you should note that as the angle increases so too does the velocity. You could measure time vs. angle; time vs. distance. Is acceleration uniform? Why do similar looking balls give different results; perhaps it is to do with their construction (see 2-piece, 3-piece and 4-piece types below. Maybe it is to do with their dimples or hardness (Novice = long, soft; Intermediate = very long & soft; Power = straight & very soft; *Titleist* = extremely long, and so on). Try removal of dimples! Use a light gate at bottom to measure final velocity; how does this compare with $2 \times v_{av}$? That's Melody's hands in the photo below. She's from Moreton Bay College.



2-piece



3-piece



4-piece



• **Stopping distance of toy cars along the floor**

For sliding friction on an incline, the coefficient of friction $\mu = \tan \theta$ for constant speed; but for rolling friction it may not be. You could let a car roll down a ramp on to the horizontal floor and see how long a distance it takes to stop. How does this vary with the angle or height; coefficient of friction of floor material; effect of weight of car and so on. What are the practical implication for this? Does twice the mass (eg a truck) mean twice the stopping distance?



Melody and Rebecca race their little yellow sports car down an incline. Year 11 - MBC.



Aimee tries out the concrete truck at MBC.



• **Settling velocity for soil aggregates**

Water-borne soil erosion impacts on river, estuary and marine resources and is therefore a major issue for Australian agriculture and catchment management. It causes unsustainable losses of soil for agriculture. Sediment eroded by water consists largely of soil aggregates (clay, mud, fine sand, coarse sand, gravel). The settling velocity of such aggregates and primary soil particles is of fundamental importance to the processes of sediment transport and deposition in water. A great EEI would be to study factors influencing settling velocity. A bottom withdrawal tube method is commonly used for the direct measurement of the settling velocity distribution of soil aggregates or particles of different sizes that settle

together. CSIRO and The Queensland Department of Natural Resources has been investigating the value of this technique for a range of soil aggregation and erosion applications. The simplest way is to take some soil – perhaps 5 grams – and add to a litre of water in a long plastic tube. Give it a shake and stand it upright and take off 100 mL or so every 10 s or so via a pinch valve in the bottom. Evaporate the water off each sample and weigh it. Methods are on the internet and are quite sophisticated. A fair bit of research will be needed to analyse and discuss your data.

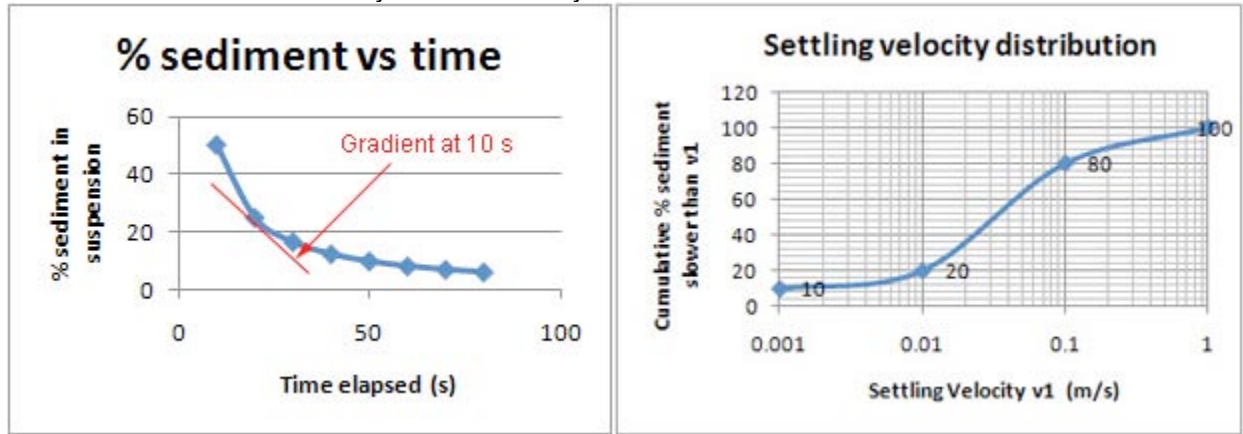

- **Hot ball bearing behaviour**

If you place a hot steel ball bearing on parallel metal track near a super-magnet, The ball sits there for a while and then zooms off. I have seen the video clip made by Mr Mark Young and his physics class at Churchie (some frames below) but just what is going on here? Something to do with cooling below the Curie Temperature. It would be an interesting experiment to try. I have a hypothesis but have never had time to test it.

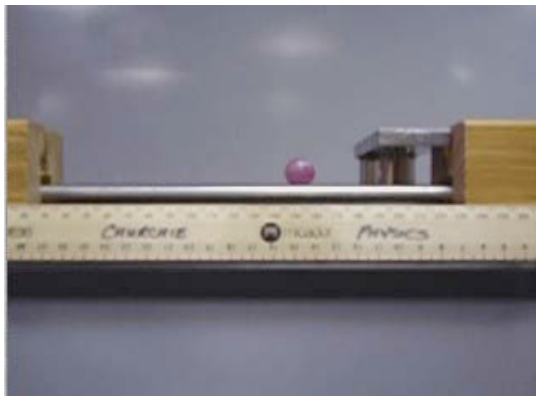

Red hot - the ball bearing just sits there

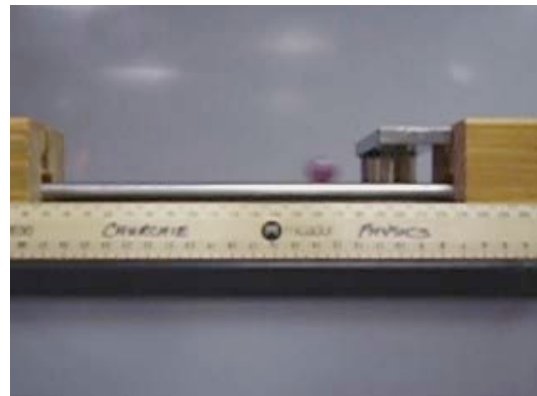

...and then takes off as it cools

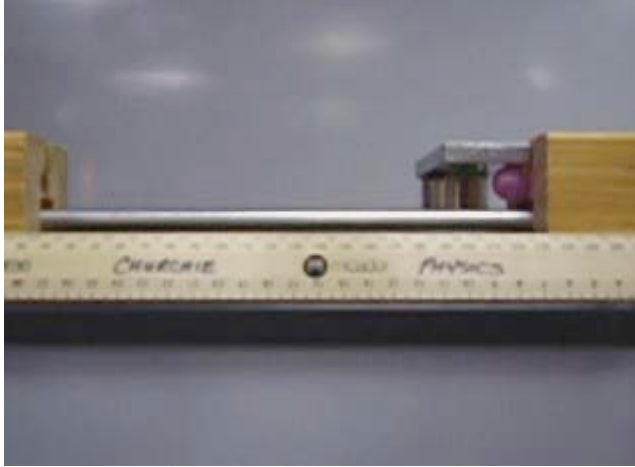

and smashes into the end at high speed

Carbon dioxide sound lens

Sound, like light, can be focussed using a concave reflector. Sound can also be focussed using a refractor - just as a convex glass lens is used for light. A biconvex gas lens will bend sound waves so that can be focussed providing the gas in the lens has a density higher than the surroundings. You could make a sound lens by filling a balloon with CO_2 (from dry ice or a cylinder). You could also make a lens by cutting two circles out of plastic sheeting and taping or gluing the perimeter. Your EEI could be to investigate how the amount of refraction varies with the different densities of the gases inside and outside the balloon, the degree of curvature, the relationship between focal length and wavelength of sound, effect of temperature, ... the factors are endless. If SO_2 wasn't so dangerous you could try that too.

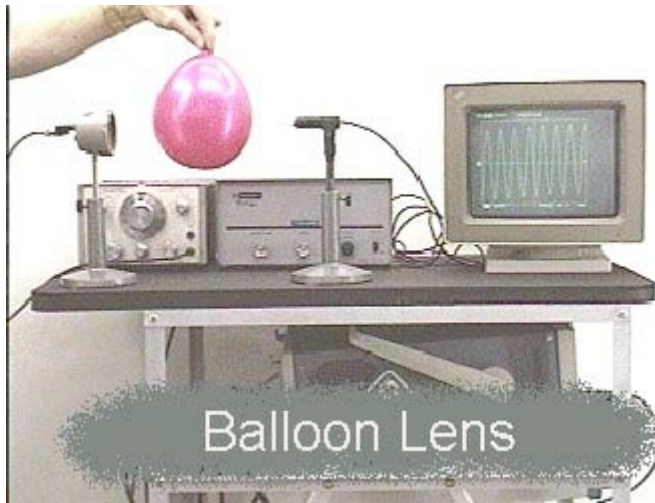

- **Submarine Buoyancy - "Up, up and away"**

Submarines have been a source of wonder, awe, fear and excitement since Bushnell built his *Turtle* in 1776. Super heroes and secret agents, in both fact and fiction, have been in and out of them quite literally for centuries. Scientists have gone to great lengths to show that the carefully faked submarine adventure of Jack Sparrow in *Pirates of the Caribbean* was physically impossible. Here's a neat EEL from Sandgate State High School courtesy of physics teacher Ewan Toombes. It goes thus: **Stage1 - Design and build** a Robot Submarine using plastic bottle ranging from a 1.25L softdrink bottle up to a 4L juice container which can be trimmed to neutral buoyancy so that it "floats" just above the bottom of the pool at a depth of 1 metre. **Stage 2 , The Escape** – Release or inject a known volume of gas into the ballast tank(s) by remote control (something that operates above but works under water that allows you to inject a known volume of gas into your submarine) that will allow it to escape to the surface carrying a "treasure" of known mass that was resting on the bottom and attached to the submarine by a slack piece of string. **Stage 3 - Measure** the acceleration of the submarine as it rises. **Stage 4 - Calculate** the acceleration it should have had due to the excess gas and use your research to explain any difference between the two. That's the start. Now think of some variables to manipulate, propose an hypothesis, justify it, design an

experiment and go and investigate. Photo taken at Sandgate SHS.

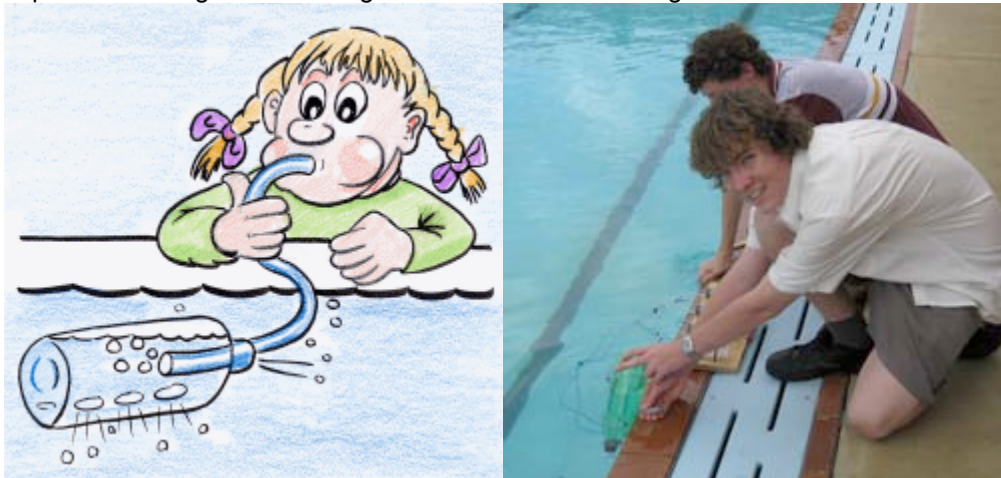

- **Slip or Tip - the limiting point for falling over**

If you stand a wooden block on it's end and give it a slow push with a pointy object (eg a pencil) it will either slide along or tip over. See figures below. The question to investigate is: what factors influence the slip or tip height? Is it friction, area of base, mass of block....? Amiee Leong (Year 12 Moreton Bay College) gives it a go.

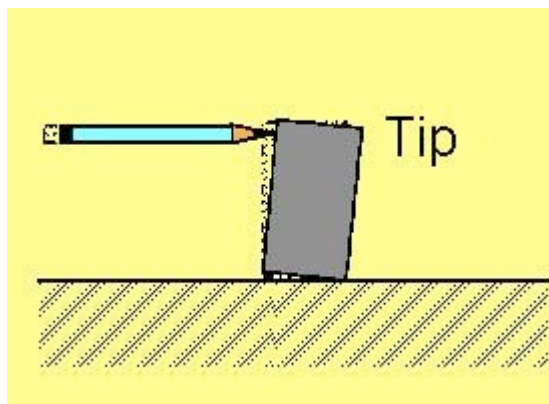
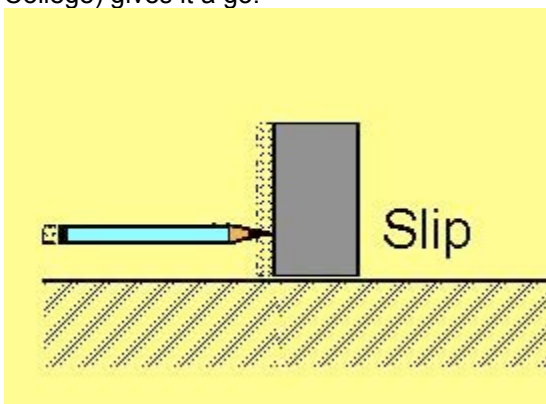

- **Coupled pendula**

If you have a rigid horizontal support such as a rod between two retort stands and hang two pendulums (pendula) of different lengths off the rod you get a strange effect when you start one oscillating. The "rigid" rod is not quite as rigid as you may think. It's not quite as simple as some books make out and in fact

makes a great EEI (particularly if you like a bit of maths). Using a non-rigid support (called a Barton's pendulum) is much easier to get the oscillations going.

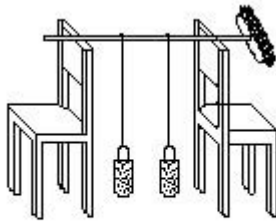

Rigid support

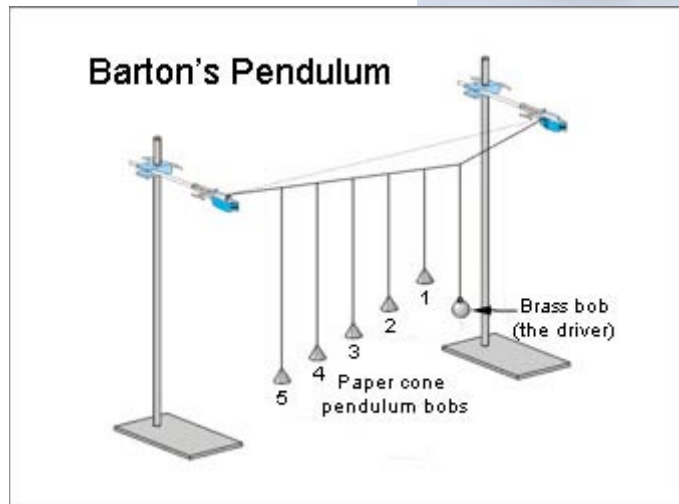
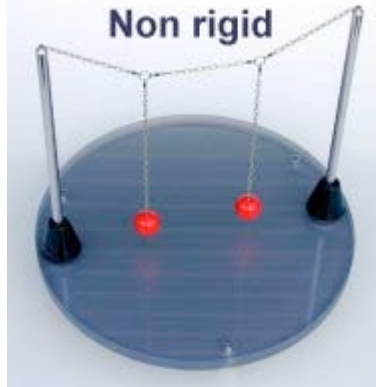

- **Coupled pendula with springs**

Another type of coupled pendula is shown below. They are solid rods or strings attached to a rigid support much the same as the figure above left (the broom). However, they have a lightweight spring attached between them. There is a great article in [Physics Education, Volume 45 No. 4, July 2010](#) about coupled pendula that provides background reading. Click the link to download it. I have only provided some of it to avoid copyright problems.

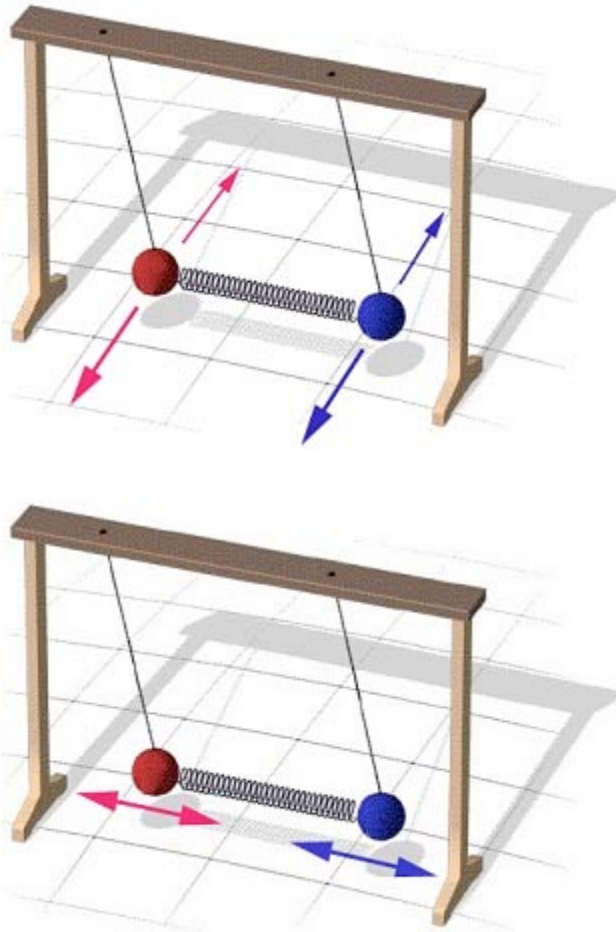

- **Battery discharge as a function of temperature**

You'd think that a frozen AA cell (battery) wouldn't work as well as one at room temperature. But how true is this? The voltage appearing at the terminals at any particular time, as with any cell, depends on the load current and the internal impedance of the cell and this varies with, temperature, the state of charge and with the age of the cell. How should you discharge the cell? What size resistor will do the trick in a manageable time? Manipulated variables: temperature, load resistance. Dependent variables: voltage or current?



- **Magnetic Braking I - sliding down an incline**

Magnetic braking relies on eddy currents. An eddy current is an electrical phenomenon discovered by French physicist Léon Foucault in 1851. It is caused when a conductor is exposed to a changing magnetic field due to relative motion of the field source (eg a magnet) and conductor. For example, when a permanent magnet moves over a sheet of metal (such as aluminium), eddy currents are set up in the metal and these can act as a brake on the motion (Lenz's Law). If you let a magnet slide down an incline on a sheet of alfoil then perhaps the braking current may be observed when compared to a control. A sheet of OHT plastic on top of the alfoil will keep it from tearing. But what if you use two sheets of alfoil separated by plastic? Or what if the alfoil is doubled in width; or twice as thick, or if the metal had higher resistance (eg Si rich iron), or the speed was slower, or faster, or the foil was slotted? Oh, the possibilities! By the way, the *Queensland Studies Authority* has an example of this EEI from James Keogh (MBC) - complete with annotations about the standards - on their webpage. It is at http://www.qsa.qld.edu.au/downloads/senior/snr_physics_07_as_eei_1209.pdf

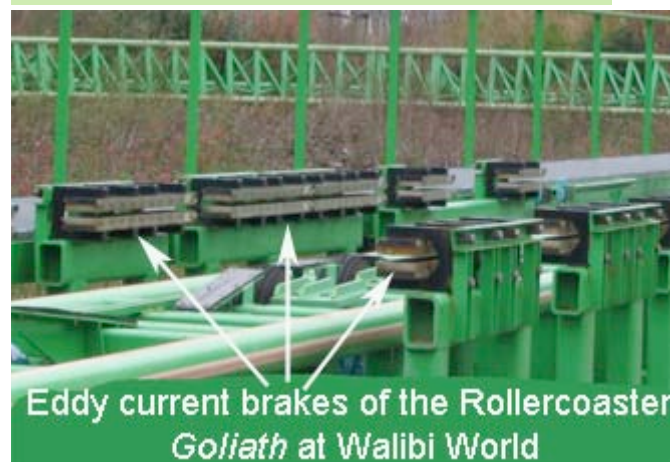
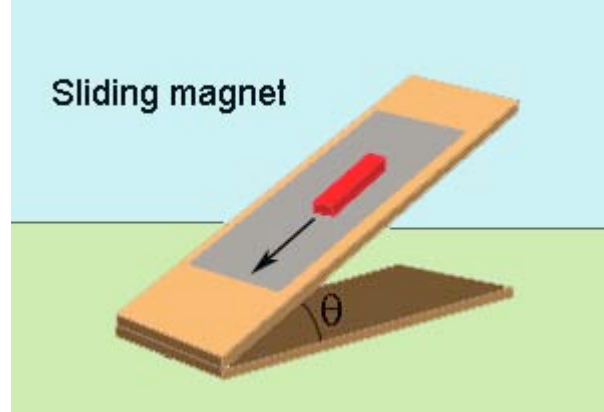

- **Magnetic braking II - model car**

The experiment described above can be varied to consider magnetic braking of a toy car. The materials I used were a simple toy car, a magnet, a slab of dielectric material (wood or plastic) and another one of a non-magnetic metal (aluminium or copper). The magnet used was of neodymium iron boron (NdFeB), which had been removed from a broken computer hard disk drive. The high level of magnetic field created by these magnets makes it possible to create interesting demonstrations of electromagnetism and electromagnetic induction and a beautiful little EEI. Fix the magnet to the underside of the car with a rubber band and let it run down a wooden incline, and then compare it to motion down an aluminium incline. It will be slower because of the magnetic braking. But how much slower. As it speeds up is the braking force still the same. Will it be less if the magnet is further away? If so, does it obey some inverse

square law. Oh what fun.

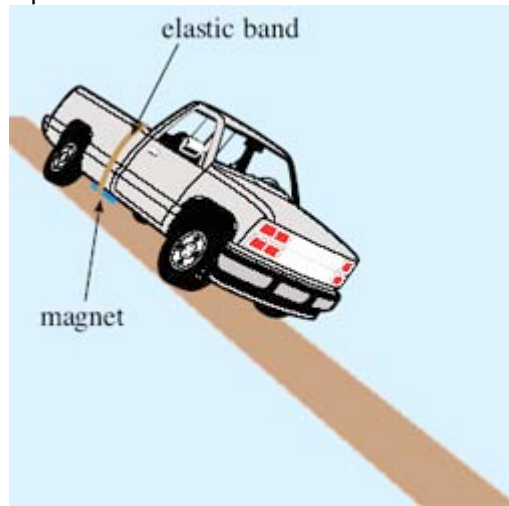

- **Magnetic braking III - rolling magnet**

A neat experiment in magnetic braking is to roll a supermagnet down a aluminium channel and compare its motion when a non-metallic (plastic or wooden) channel is used. I've tried it and it works like a charm. However, I wonder if the braking force is related to the speed of the magnet (if so, why?) and this could be investigated by varying the angle. There is a little bit of friction with the walls of the channel but this would be similar for the non-metal and possibly could be calculated as it would be common to both. Would cutting slots in the channel make any difference? If you think so you'd need to work out why and justify your conjecture first. The bait cast fishing reel in the photo below is one that uses magnetic braking to prevent backlash when casting. It provides some sort of counter torque.

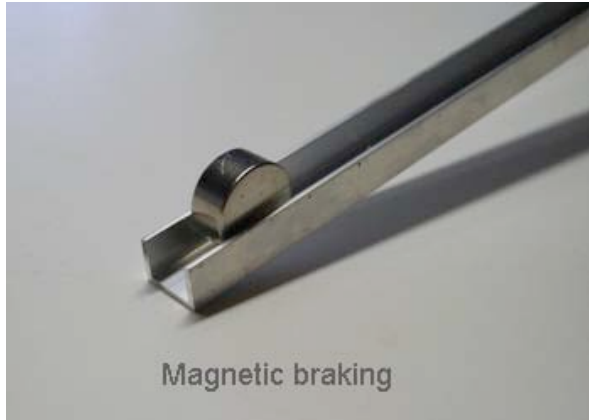

Magnetic braking IV - pendulum

A final suggestion is to investigate a supermagnet pendulum. If a pendulum is allowed to oscillate between two pieces of aluminium (or other metal) the eddy currents should slow it down. You could compare a freely swinging magnet with the same one swinging as in the photo - between two aluminium slabs (I used two hotplates on their sides but I could detect some attraction to some hidden iron). One difficulty is coping with terrestrial magnetism which loves to interfere. Some variables: length of string (related to period and hence speed), distance between plates. I had a good time with this until the bell went for the end of lunch.

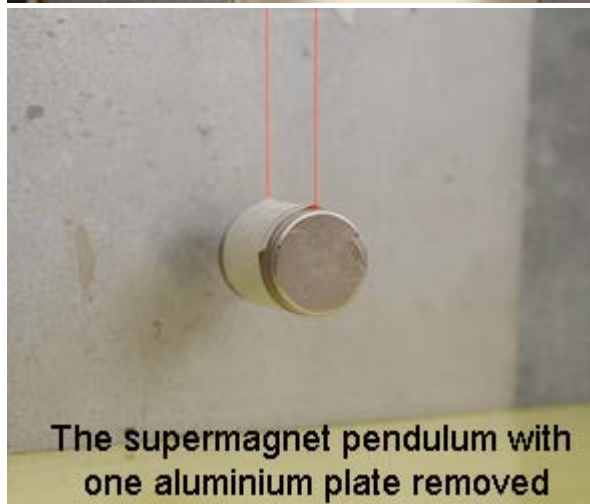
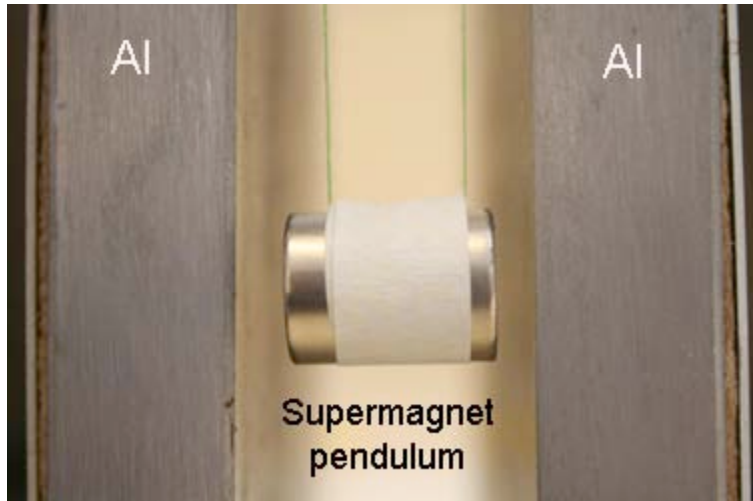

- **Forces of an rolling magnet**

When you roll a cylindrical magnet down an inclined plane, it is deflected to the left or right from its original direction depending on the initial orientation of its poles with respect to the Earth's magnetic field (see diagram below). A good EEI would be to get a sheet of non-magnetic material (why?) - such as a sheet of plastic or wood and clip a sheet of paper to it with a line drawn down it's middle. Raise the board to a measured angle and let the magnet roll down, noting it's path, and the orientation of the board with respect to the earth's field. Reverse the magnet and try again. Try different angles and different orientations. What a fabulous EEI. Moments of inertia of a solid cylinder, and the formula for torque may

help.

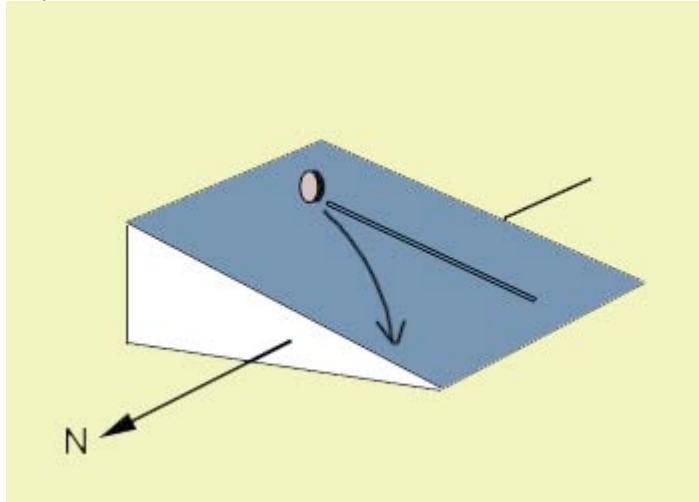

- **Measuring the Earth's Magnetic Field Strength**

A century ago, the Earth's Magnetic Field Strength (B) was measured by observing a suspended bar magnet oscillate in a horizontal plane. A new device was invented whereby a coil of wire was spun in different directions and the voltage noted. You could try this and get some interesting results. The bigger the coil, or the more turns, or the faster it is spun - the greater the voltage (Faraday's Law). You could make a big one out of wood like in the photo below, or make one out of a plastic fishing reel (below) with an axle glued in place and spun by hand or in an electric drill (with care). You'd have to work out how to hook up the moving coil to a stationary voltmeter. And how would you measure the speed of rotation: stroboscope, stopwatch? There is a formula $E = E_0 + 2\pi NAB/T$ which has the form $y = mx + c$ and can be investigated (plot E vs $1/T$ to get the slope $2\pi NAB$). You would have to try spinning it in different directions to see how B varies with the angle, and with speed. A fun EEL if ever I saw one.



- **Crash Cushions**

Crash Cushion (or Crash Attenuators) are rubber devices that protects the motorist from a blunt object such as concrete wall or guard rail. Inside of the cushions is a very high density foam. As the vehicle hits the front of the system, the system collapses and these devices cushion the impact; like an accordion. You could model a barrier and decide on optimum type of material and size. Variables: perhaps force vs. compression, deceleration vs. thickness, mass of vehicle vs compression. Look at KE, momentum, impulse, spring constant.



Crash Cushion Attenuator



Testing Rig

- **Medical physics - blood oxygen and altitude using a pulse oximeter**

Here's a difficult EEI that may be of interest if you are thinking medical physics. It looks at the changes in blood oxygen with altitude using a device called a "pulse oximeter" - a clip-on sensor used in hospitals to monitor oxygen saturation in the blood. You'd have to have access to one of these. The body is remarkably effective at maintaining blood oxygenation at a constant level, typically between 95 and 100% (meaning that arterial blood is carrying between 95 and 100% of the maximum amount of oxygen that it can possibly carry). However, if you climb a mountain, it is found that blood oxygenation levels reduced by 6% per 1000 m of ascent. Pulse oximetry is based on the different absorption spectra of oxygen-rich *oxyhaemoglobin* and oxygen-poor *deoxyhaemoglobin* at red and near infrared wavelengths. It exploits this difference by shining two wavelengths of light, one red and one near infrared, through tissue and measuring the resulting light intensity. Two light sources, usually LEDs at wavelengths of around 650 and 900 nm, are held at one side of a convenient site (typically the finger or earlobe in adults, or the foot in babies) and a photodetector held opposite records light transmitted through the body. So, if you are planning a skiing or hiking trip with a group of people you could measure O_2 levels at different altitudes, across a wide range of people (different ages, skin colour, weights) and see what you get. Developing and testing an hypothesis is the main challenge. Look at the criteria for your EEI and see how you may meet them. See *Physics Education* 2009, V44 (6), p 577.

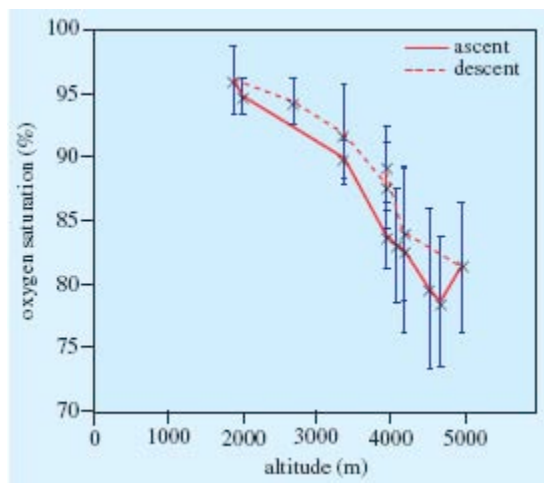

Surface Tension of liquids

You've seen examples of surface tension in action: water striders walking on water, soap bubbles, or perhaps water creeping up inside a thin tube. Surface tension is defined as the amount of energy required to increase the surface area of a liquid by a unit amount. So the units can be expressed in joules per square meter (Jm^{-2}). You can also think of it as a force per unit length, pulling on an object. It can be used to explain why sap rises in trees, how the surfactant works in our lungs and why waterproofing agents work. You could construct a simple balance to make some measurements (see below). Your EEI could look at how surface tension changes with concentration of solute (eg soap) or with temperature. If you choose to compare the surface tension of different liquids then you'd have to have a reason (in terms of physics principles) for doing so.

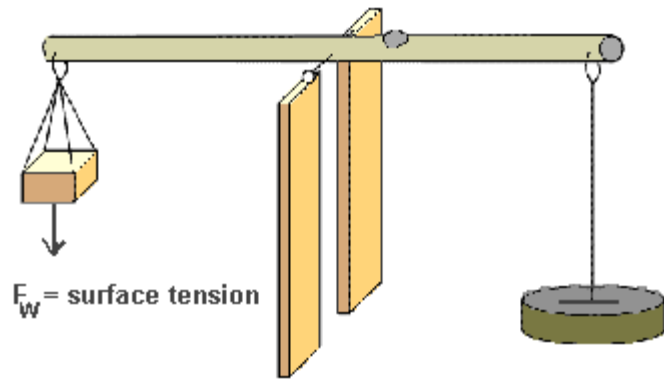
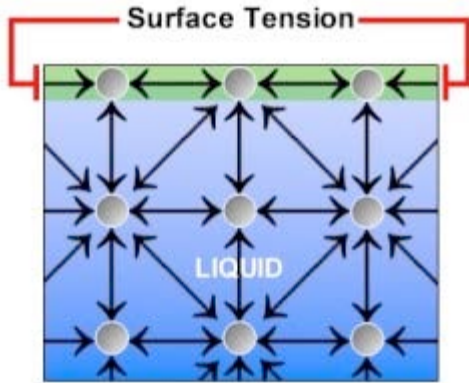

- **Coupled pendula - metronomes on a skateboard**

I've never tried this but I've been told it works. If you set two metronomes to the same frequency and place them on a skateboard (or a base that is free to move), they will not be synchronised and will get out of step. However, if you wait long enough they will synchronise and become 'phase locked' or 'mode locked' as they are forced to endure the driving force of each other. Biology abounds with examples of synchronization: cells in the heart beat together, audiences often applaud together, fireflies in South-East Asia flash in synchrony, cicada emerge together, etc. The earliest known scientific discussion of synchronization dates back to 1657 when Christian Huygens built the first working pendulum clock. Huygens studied systems of two pendulum clocks mounted on a common base. He observed that the clocks would swing at the same frequency and 180 degrees out of phase. This motion was robust, after a disturbance the synchronized motion came back in about half an hour. Huygens spent some time exploring this curious phenomenon. You could investigate what starting conditions are necessary for phase locking. Maybe start with *prestissimo* (208 Hz) which is the fastest setting and make them 180° out of phase. No more hints but you should see the amazing demo on You Tube:

<http://www.youtube.com/watch?v=W1TMZASCR-I>

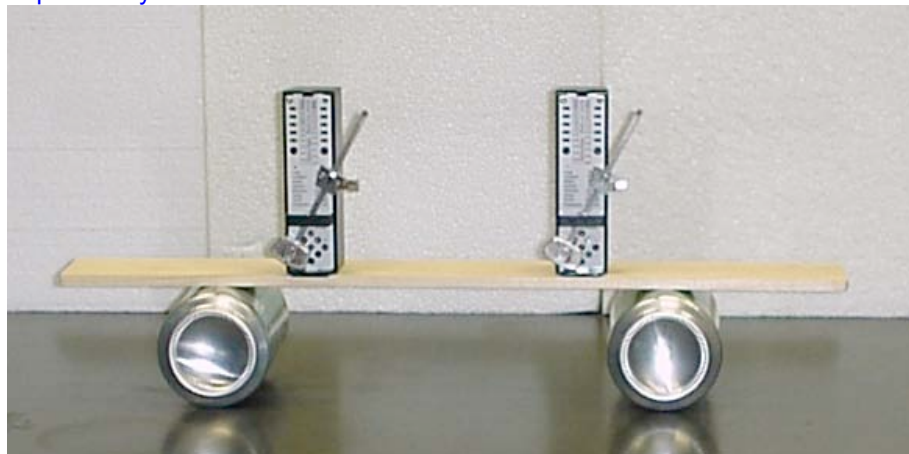

• **Doppler Effect of source moving in a circle**

The rise and fall in pitch of a sound source as it move towards and away from you can be simulated using a small 9 volt buzzer (from Dick Smith) and battery attached to a rotating platform. I've seen a 100cm aluminium bar attached at it's centre to a small electric motor. If the buzzer is at one end, the battery in the middle and a counterweight at the other end, you'll have endless fun. Fix a microphone to the benchtop 50 cm from the motor. Record the sound at rest and then at different speeds. Analyse using spectrogram software easily obtainable on the web (eg *Audacity*). Does the Doppler formula agree with the results. If not, why not? Would something generating a pure tone be better (eg an iPhone audio function generator app). Does the accuracy of the formula depend on frequency? Feedback on this EEI comes from Rachelle East from Genesis Christian College, Bray Park, Queensland: "A group of my girls last year did the Doppler effect experiment. It was a fabulous one to do".

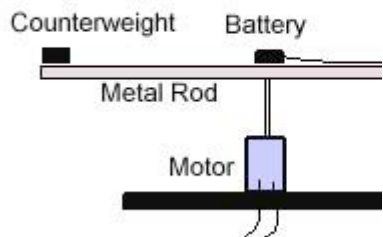

Doppler setup.



Set up used by Physics student Cody Gilchrist of Thuringowa State High School, Queensland for his Doppler experiment. Physics teacher Katrina Manz said that Cody obtained great results from this apparatus and produced an equally good EEI report.



Joel Goodwin and Paige Kurmass work on their Physics EEIs in the lab of Katrina Manz at Thuringowa SHS. Cody Gilchrist's Doppler Experiment setup is on the front bench.

• **Doppler Effect of source moving on a pendulum bob**

Similar to the one above but with the buzzer attached to a pendulum bob. You can calculate the speed

mathematically at any point on it's journey and relate this to the waveform. Would a long string or a short string be better? Where should the mike be placed? No more hints!

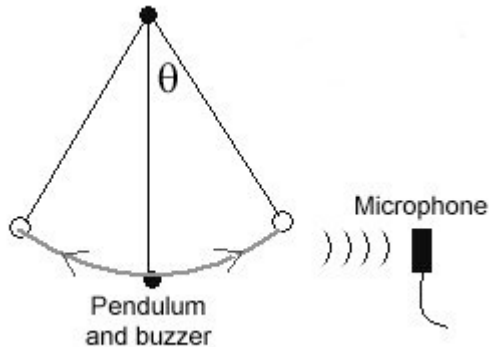

- **The Large Amplitude Pendulum**

Speaking about pendula, the formula for a small amplitude pendulum $T = 2\pi\sqrt{l/g}$ has to be modified when a larger angle (eg up to 90°) is used. The modified formula can be found in newer university physics texts and on the internet. However, you could investigate the effect for yourself and see if the modified formula really is an improvement. Just remember that the approximation $\sin\theta = \theta$ when the angle is in radians. One hypothesis could start "if the release angle is increased then the accuracy in measuring 'g' will when the mass of bob and the length of the.....are kept.....".

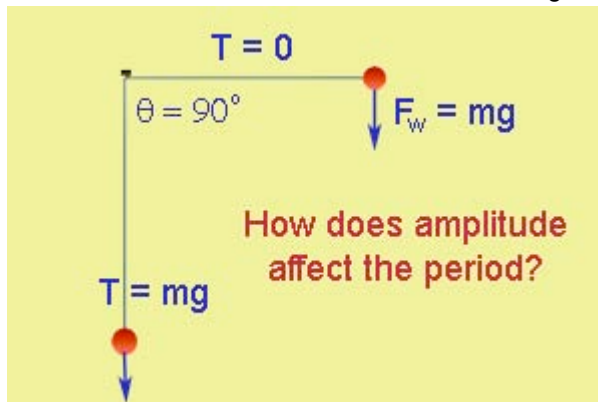

Simple Pendulum - feeling the Tension

To measure the period (of one oscillation) of a pendulum accurately, you usually measure the time for 10 oscillations and divide by 10. When your manipulated variables are length (L) or mass (m) you make angular displacement (θ) a controlled variable. However, this is a bit of a lie as the angular displacement decreases with every oscillation - it is not constant. I know it is not much but could be a significant source of error. It comes about from the friction of the bob in air, and, of the friction between chains of molecules in the flexing (bending) of the string or nylon fishing line at the top. The intramolecular forces between nylon polymer chains in *nylon 6, 6* are the quite strong hydrogen bonds so the loss of energy could be significant. But as you know from your study of SHM, the forces on the bob are not constant - they are the least when the bob reaches it's maximum displacement (see figure below). So if you could measure the tension (T) in the string with a force sensor and capture the data with a laboratory interface, a plot of force vs. time should give you the peaks that you need. I won't say any more; this could be a great EEI.

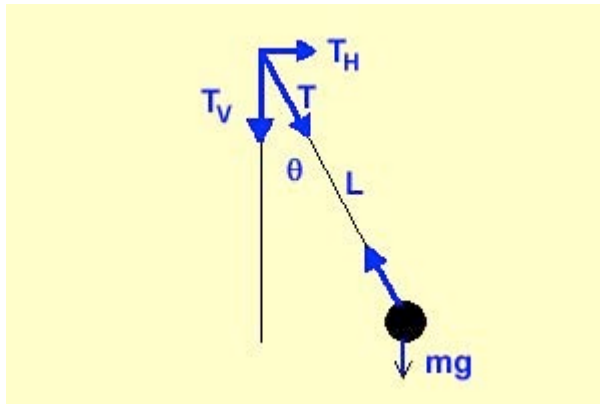

- **Optimising a solar water heater**

Build a model from designs you can find on the internet; determine what you are going to measure (rate of temp increase perhaps), then optimise or at least determine the effect of changing various variables (area, number of tubes, paint colour (gloss vs. matt), glass thickness (one sheet, two sheets etc). You should be able to hypothesise what the changes will do to the measured variable. Are there any mathematical relationships? Are any unexpected? Watch that your controlled variables (eg sunlight) really is controlled.



- **Variation in soil temperatures with depth**

You may have seen people living underground in hot place. For instance at Coober Pedy, the hottest place in Australia, the locals have made their homes beneath the surface as the soil remains cool. Even when the outside temperature reaches 45°C, the inside stays about 21°C. The daily variation in radiation experienced by a soil surface causes the temperature at the surface to vary widely during the day. The radiation level will change with the angle of the sun, at night, during cloudy days, during rain, or in different seasons. This is called diurnal (daily) variation. But the fluctuations beneath the surface are another thing. The extra time taken for a particular depth to reach maximum temperature is called “phase delay”. A great EEI would be to look at the fluctuations at various depths (0 cm, 10 cm and so on) as a heat source is applied and removed at the surface. Maybe get a plastic pipe, drill holes every 10 cm or whatever, fill it with the soil being investigated, stick some thermometers in (or temperature probes) and place a heat lamp at the end and turn it on for 30 minutes and then off for 30 minutes and so on. If you had a datalogger and a electronic timer for the lamp you could leave it go for a few days. You get a square wave of heat – but that’s okay. Soil scientists tell us that the rate of change of temperature at any depth is proportional to the second spatial derivative of the temperature profile (but that is way to complex for Year 12, and me).

Underground home at Coober Pedy

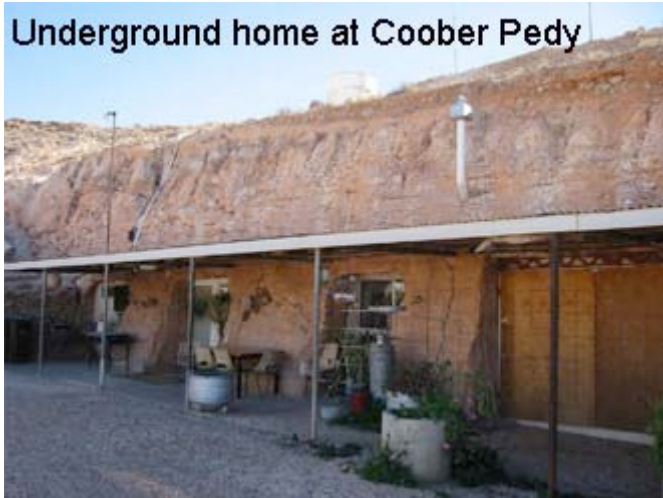

Soil temperature

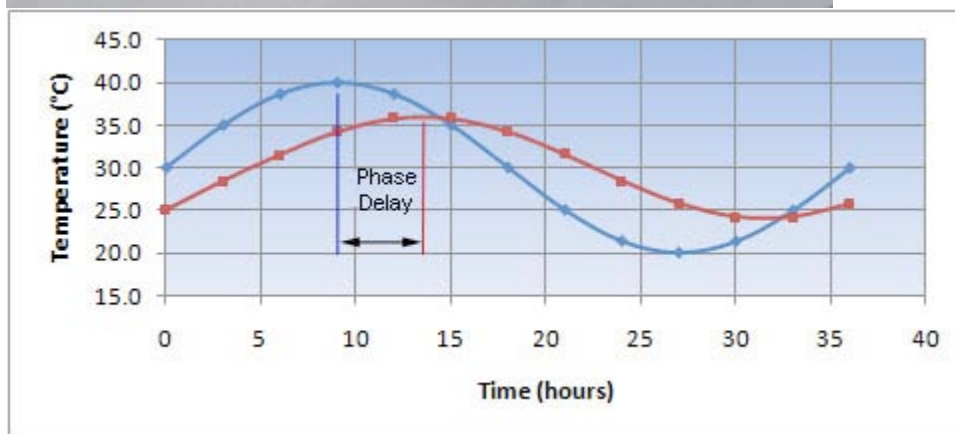

- **Concrete hydration**

The importance of concrete in modern society cannot be overestimated. Look around you and you will find concrete structures everywhere such as buildings, roads, bridges, and dams. There is no escaping the impact concrete makes on your everyday life. Concrete is prepared by mixing cement, water, and aggregate together to make a workable paste. It is molded or placed as desired, consolidated, and then left to harden. Concrete does not need to dry out in order to harden as commonly thought. The concrete (or specifically, the cement in it) needs moisture to hydrate and cure (harden). When concrete dries, it

actually stops getting stronger. Concrete with too little water may be dry but is not fully reacted. The properties of such a concrete would be less than that of a wet concrete. The reaction of water with the cement in concrete is extremely important to its properties and reactions may continue for many years. You could make up thin slabs of concrete in a shallow trough with different amounts of water and test their breaking strain. What if you were unable to get fresh water - would seawater be just as good? The possibilities are endless.



Sample preparation



and testing

- **Hysteresis and rubber bands**

When you stretch a rubber band and then let it go, you can notice that the band does not behave like a spring. A rubber band, made of latex and rubber, does not return to its exact original shape after being stretched. This is an example of a phenomenon called hysteresis. Small vehicle suspensions using rubber (or other elastomers) can achieve the dual function of springing and damping because rubber, unlike metal springs, has pronounced hysteresis and does not return all the absorbed compression energy on the rebound. Mountain bikes have frequently made use of elastomer suspension, as did the original Mini car. By studying the relationship between the rubber band during stretching and unstretching as weights are added or removed, you can determine the amount of work done on the rubber band, the amount of energy (in joules) lost by the band and plot a hysteresis curve. Of course, you'd need more than one rubber band.

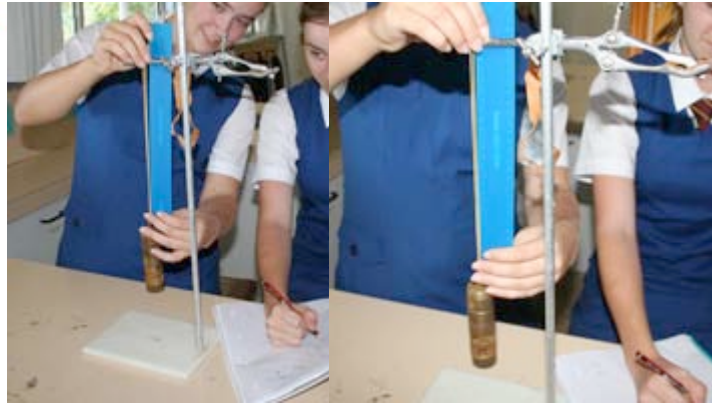
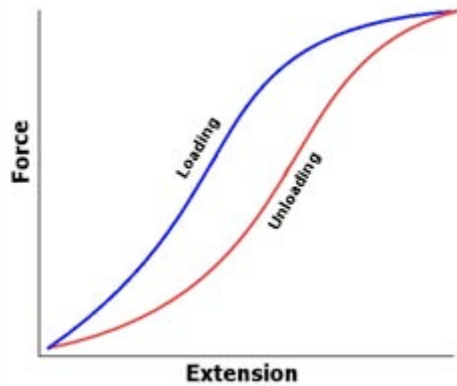

- **Buckling Height**

Galileo pointed out in 1637 that an animal's bones must be proportionately stronger, therefore thicker, in a large land animal if they are not to be crushed by the animal's own weight; hence the mass of the skeleton must rise relatively greater than body mass. This is also of concern in the growth of trees and in the design of vertical beams for buildings (eg cylindrical piles). You could investigate how the strength of a hollow cylinder varies with diameter when keeping the mass and length the same. Maybe use cylinders of rolled-up A4 paper and look at crush loads for different diameters and configurations (cylinder, oval, square, rectangle).

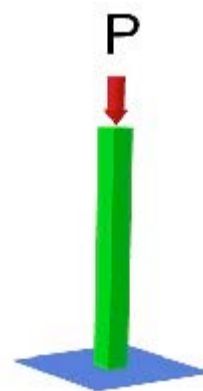
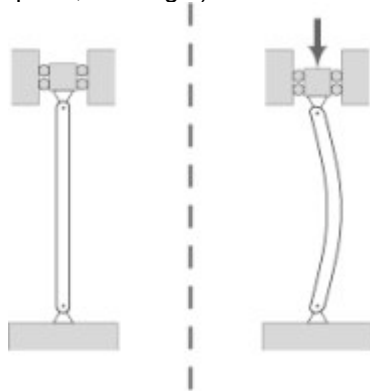

- **Pressure/Depth Sensor**

The deeper you go into a liquid, the greater the pressure on you from the surrounding liquid. This is the principle behind the depth charge - an anti-submarine weapon intended to defeat its target by the shock of exploding near it. Most use explosives and a fuze set to go off at a pre-determined depth. Would it be

possible to design and build a device (not a bomb, just a sensor) that responds to increasing pressure with depth and a LED turns on at set depths? You'd have to figure out a pressure sensor and then try out a model in a swimming pool. It sounds very hard but could be a great EEI.

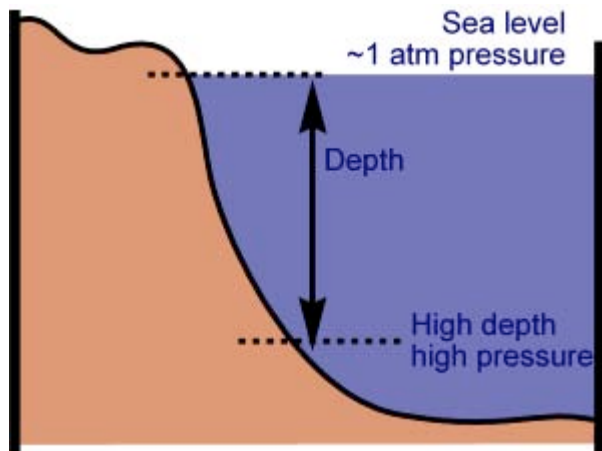

The Gaussian Gun

If you arrange several steel ball bearings and a strong (Neodymium) magnet as shown in the picture, you are on the way to constructing what is called a Gaussian Gun. When a single ball bearing (far left) is given a gentle push it is accelerated towards the magnet and strikes it at high speed. The ball to the far right shoots off at a higher speed. Why? That's for you to work out and what factors are involved. If the final ball the strikes another set of magnets and balls mayhem ensues. There are many factors to examine here: but the number of balls on the right, and the distance between these and the next are vital. How to measure things - that's the question; maybe some photogates. You could even make a multimagnet gun for extra velocity. Have a look on *You Tube* to see some in action.

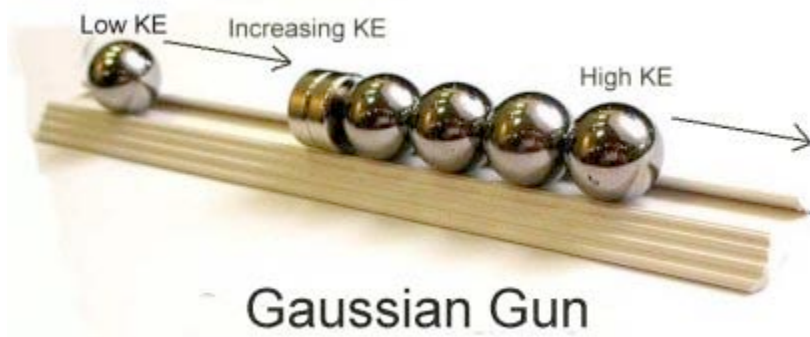

Gaussian Gun

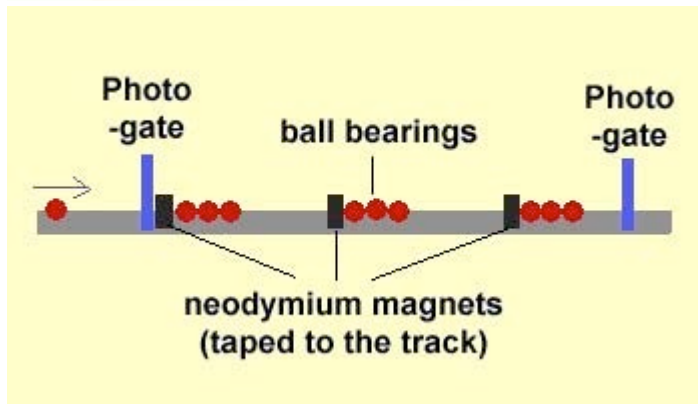

- **Fresnel lenses and magnification**

Magnification of an overhead transparency on an overhead projector (see below); dissect an old one with the power cord removed to examine the optics; or open up a new one; what thickness lens would be needed to replace the Fresnel lens (pronounced *Fr-nell*); is magnification related mathematically to the

distance between object, Fresnel lens, top lens and screen?



- **Strength of spaghetti strands**

Spaghetti makes an interesting substance for modelling structures. Three civil engineering students (pictured below) designed and built a bridge weighing 193 grams that was capable of supporting 53 kilograms. The use of spaghetti is a great way to demonstrate some basic principles of engineering because it reacts to the five internal stresses and strains within a structure – tension, compression, bending, shear and torsion. For an EEI individual strands can be investigated for their strength by hanging weights on middle of horizontal strand. You could measure displacement ('sag') vs weight for various span widths; or different diameters of the strand. I'm told the sag varies with the weight according to a 4th-power rule; and the diameter vs sag is an inverse cube relationship. But that's only hearsay.



- **Gyroscope spinning in the one plane**

A spinning object on a moveable axis will keep spinning in the same direction even if the supports move. The first practical use was for an artificial horizon in British ships in 1744. The gyro-compass was invented in 1908. But under what conditions will the axis remain in a fixed position? What of bearing friction, rotational speed?

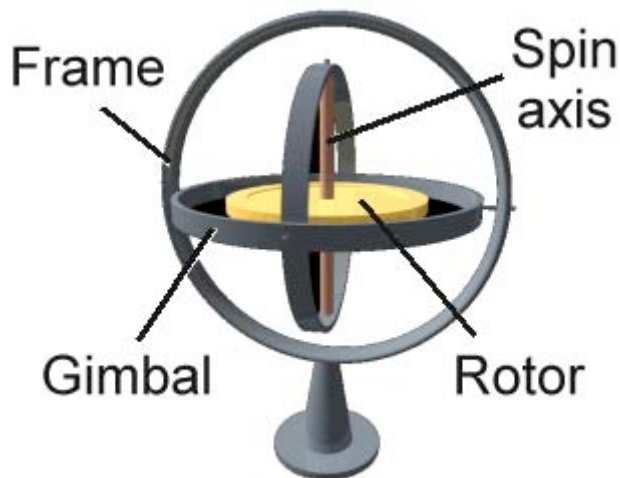

- **The 555 Time Machine**

The 555 microchip is an integrated circuit invented by Hans R. Camenzind in 1970 and introduced to the world in 1971. Using simply a capacitor and a resistor, the timing interval can be adjusted and so can be used for numerous applications including timers, clocks, switches, security alarms and tone generators.

Circuits are freely available on the internet. An idea for an EEI would be to test the accuracy of the timing circuit. The problem is - how do you measure it's accuracy when the stopwatch you would used is based on a 555 timer anyway? Perhaps you could see if the error is related to the tolerances of the resistor and capacitor; or perhaps you could make a few of them and see how they vary; or perhaps you could see how reliable they are with varying temperatures.

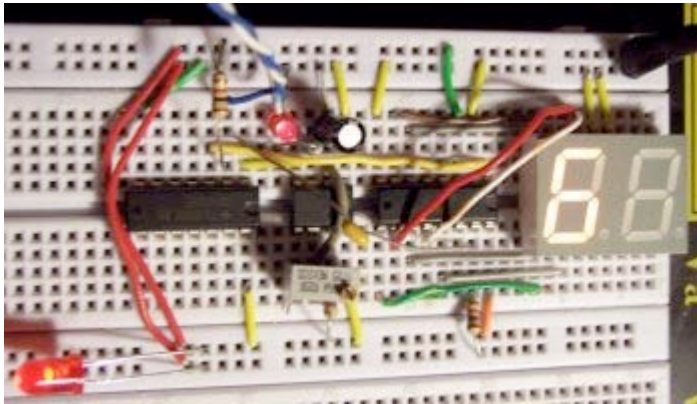
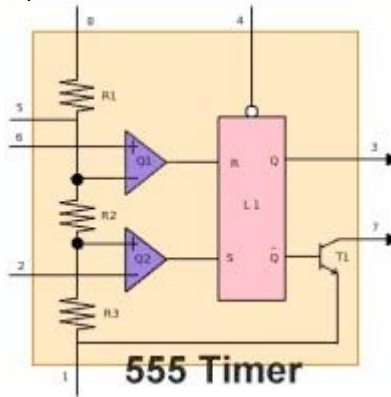
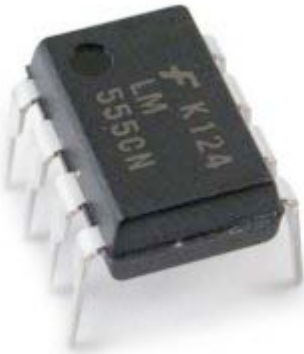

- **Pulling a spool of cotton by a thread**

An old favourite: investigate the conditions for rolling forward or backward; angle; effect of weight and surface friction - see diagram below. Again, why would you want to know this? Aimee Leong tests this out.

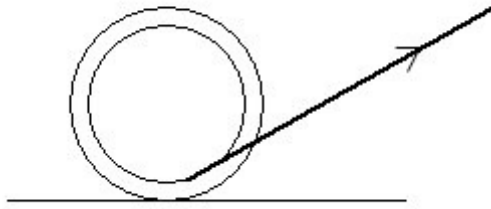

- **The Kelvin water dropper**

The Kelvin water dropper, named for Lord Kelvin (William Thomson), is a type of electrostatic generator. Kelvin referred to the device as his water-dropping condenser. The device uses falling water drops to generate voltage differences (up to 6000 V) by utilizing the electrostatic induction occurring between interconnected, oppositely charged systems. It is possible to build a very simple high-voltage generator which has no moving parts. By dripping water through some old soup cans, several thousand volts magically appear. An EEL would be to investigate the conditions under which the potential differences appear: size of cans, distance drops fall, rate of flow and so on.

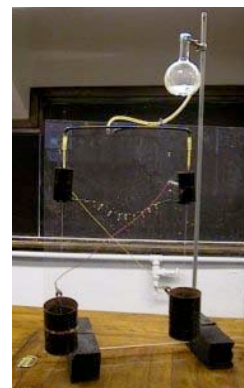
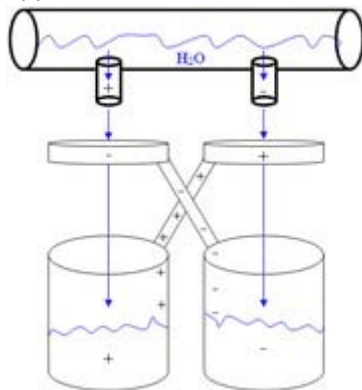

Turbine efficiency

This EEL models a device known as a "fluid coupling" similar in many ways to the processes occurring in the automatic gearbox of a car. A fluid coupling is a hydrodynamic device used to transmit rotating mechanical power from one part to another. It also has widespread application in marine and industrial machine drives, where variable speed operation and/or controlled start-up without shock loading of the power transmission system is essential. In essence it consists of two turbines (fan like components): one connected to the input shaft; known as the *pump*, *impellor* or *input turbine*. The other connected to the output shaft, known as the *output turbine* or just plain *turbine*. A good investigation would be to see what factors affect the efficiency of the conversion of mechanical energy from one fan to the other. You could do this with air as the fluid, or try it in water or oil (your teacher may hate you using oil in the lab at it makes one enormous mess and is hard to clean up). For a more viscous water-based liquid you could start with honey and gradually dilute it. The photo below uses a low-voltage motor turning a fan to provide the wind, which blows against another fan to drive a low-inertia dynamo (the turbine). It is up to you to develop an hypothesis and a way of measuring input and output energies (perhaps using a voltmeter). An efficiency vs speed graph would be fascinating.

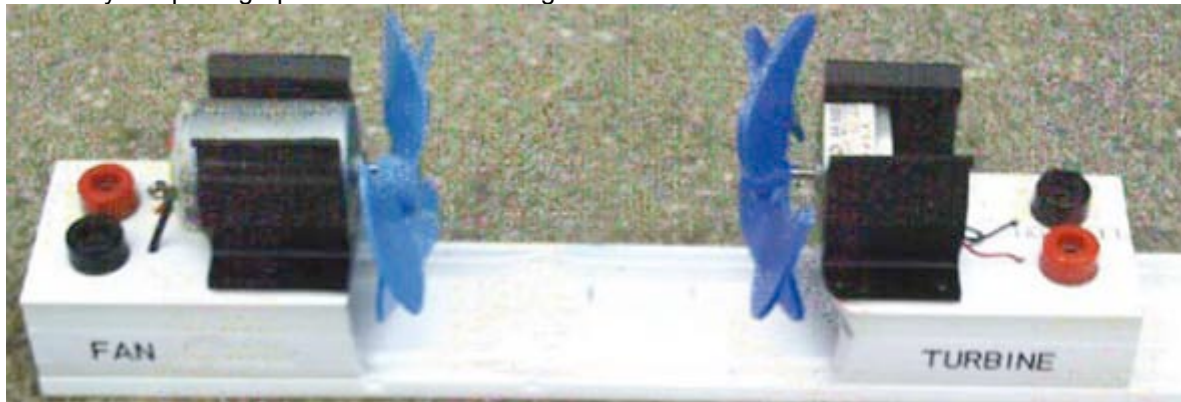

- **Windpower: the world of carbon reduction.**

Wind energy is plentiful, renewable, widely distributed, clean, and reduces greenhouse gas emissions when it displaces fossil-fuel-derived electricity. It is considered to be more environmentally friendly than many other energy sources and worthy of our investigations. Most wind turbines seem to be 3-bladed whereas domestic fans seem to be 3, 4, or 5 bladed. As well, wind turbines can have adjustable blade angles. You could make some model turbines hooked up to a small electric motor and measure the voltage produced when you blow air on it. How does blade angle, blade length, number of blades etc affect performance?



Wind farm - all 3-blade
Are three better than four?



Variable pitch blades
Need to decrease the pitch in high winds or else.



Home-made fan using cardboard blades



Buy a fan and run it backwards as a generator.

- **Yagi Transmitter**

A Yagi-Uda antenna is familiar as the commonest kind of terrestrial TV antenna to be found on the rooftops of houses. It is usually used at frequencies between about 30MHz and 3GHz, or a wavelength range of 10 metres to 10 cm. You may know that they are directional and when being installed they have to be rotated until the strongest signal is found. A Yagi transmitter has a characteristic pattern of signal strength as shown in the figure below. An EEI that a Year 12 radio enthusiast from Sandgate State High School (Brisbane) undertook was to study the radiation pattern of a halfwave 5-element Yagi antenna transmitting a signal from a 147 MHz VHF transmitter. Suggested dependent variables are distance and angle. If this means nothing to you then this EEI would not be any fun. If you are in to radio communications or know a ham-radio enthusiast then it could be good. The student was Gal Strasberg (seen below) and his physics teacher was Ewan Toombes. You don't need to make the antenna - just buy one. And you'd have to buy, borrow or hire the VHF transmitter and the field strength meter. Gal bought the transmitter online from a radio communications supplier (Andrews Communications), and the built the field strength meter himself using a basic tuned circuit similar to the one at:

<http://www.zen22142.zen.co.uk/Circuits/rf/fsm.htm>



- **Theremin Synthesiser**

The Theremin is a device that detects changes in the electromagnetic field that it radiates and by use of clever electronics uses the changes to alter the frequency of a sound generator. It was used in the construction of the Keck Observatory in Hawaii. As the Keck's mirror was 4 times larger than any other built before it, careful alignment of the mirrors was essential. The Theremin could detect changes in the position of objects down to nanometres. For an EEI, why not build a **Theremin** from a kit and investigate what changes its output? Jaycar Electronics (Aust.) has them for about \$60. The sound is produced by the interaction of two radio frequency oscillators which normally are operating above the range of human hearing. However, if one of these oscillators is slightly detuned by varying it's frequency (by placing objects near it to change the capacitance) while the other oscillator remains fixed, the difference in the frequencies (known as the beat frequency) is in the audible range and can be amplified. This process is known as heterodyning. It is a weird sort of electronic musical instrument that you play by moving your hands in the magnetic field that it puts out. Its definitely a strange sort of gizmo and would be a pretty good thing to keep once you have finished your EEI. You can make all sorts of sci-fi effects like in the old flying saucer movies and the sounds from The Beachboys song *Good Vibrations*. Click here to listen to some [Theremin music on YouTube](#). WARNING: the important part of your EEI won't be in building it but

in using it to test your hypotheses.

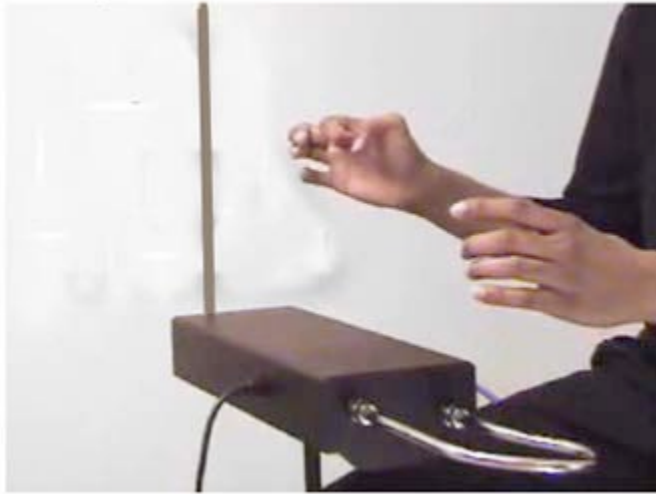

- **String unwinding on a pole**

Measure time for n turns; variables: initial length, radius of pole, angle, weight of bob, speed, amplitude.

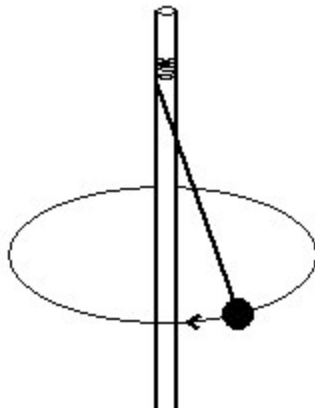

Rebecca (Moreton Bay College) starts it off with 9 turns around the stand.

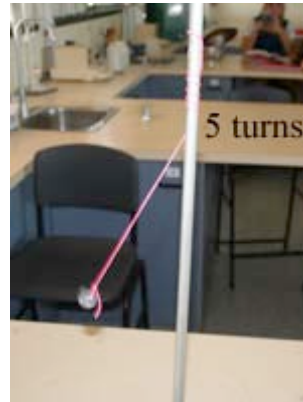

When 4 turns have unwound (leaving 5 left to go) the amplitude was 10 cm.

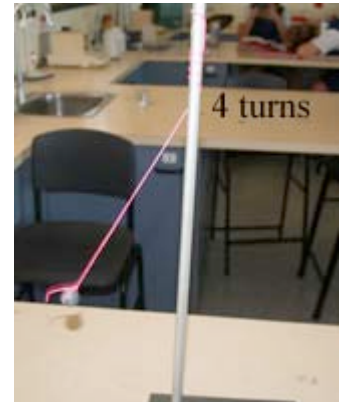

When 5 turn have unwound the amplitude is 15 cm and the speed is even greater.

- **Kicking a football**

Measure time of contact using Alfoil strips on the ball and shoe as a timing switch; measure time of flight, range, angle, pressure).



- **Electric strain gauge**

A strain gauge is a device used to measure the strain of an object. Invented in 1938, the most common type of strain gauge consists of an insulating flexible backing which supports a metallic foil pattern. The gauge is attached to the object by a suitable adhesive, such as superglue. As the object is deformed, the foil is deformed, causing its electrical resistance to change. You could compare one to a length of nichrome wire and measure its resistance as weights are added; try parallel; try other wire. Do they behave in a similar fashion? If not, why not?



Strain Gauge glued to a bolt



Strain Gauge installation



Roller Coaster Loop-the-Loop

Have you noticed that the loops in a roller coaster rise are not circular; they are ellipses. The reason is to do with the maximum centripetal acceleration the body can take before blacking-out. Now, they don't want you to black out as it would hold up the ride, and you wouldn't be able to go and buy their overpriced food. Model one using flexible track and try varying ratios (major axis : minor axis). Vary the speeds; contemplate conservation of mechanical energy. What are the various combinations of speed and axis ratios needed to keep acceleration below the safety limit?

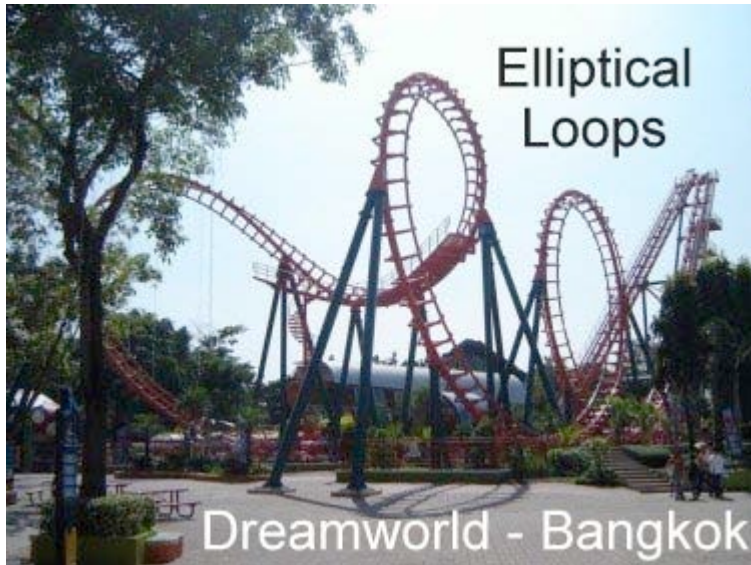

- **Air damping**

A 'damper' is a device that eliminates or progressively diminishes vibrations or oscillations. A shock absorber in a car deadens (dampens) the up-and-down movement because it contains a dampner called a dashpot which resists motion via viscous friction. The resulting force is proportional to the velocity, but acts in the opposite direction, slowing the motion and absorbing energy. Vertically suspend a brass 'weights' hanger from a spring and measure oscillation period as masses added; then make a cardboard damper and try again. Is decay of period logarithmic? Vary area of damper.

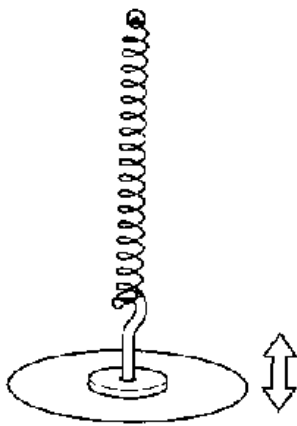

AirPot[®]
Air Damping Dashpot

- **Modelling sporting equipment as solid pendulums**

The "sweet spot" for a piece of sporting equipment is the region of the bat or racquet which gives players the optimal result from a stroke. It is sometimes said to be the centre of mass, centre of percussion, the power centre, the area that gives the most bounce, the area which gives the least vibration to the holder's hands etc etc. There are twenty different definitions on the web. A good one to investigate is the centre of percussion (where a perpendicular impact will produce translational and rotational forces which perfectly cancel each other out). Another is to model the bat to a solid pendulum. You could make a comparison of

a cricket bat, baseball bat etc with metre ruler etc.

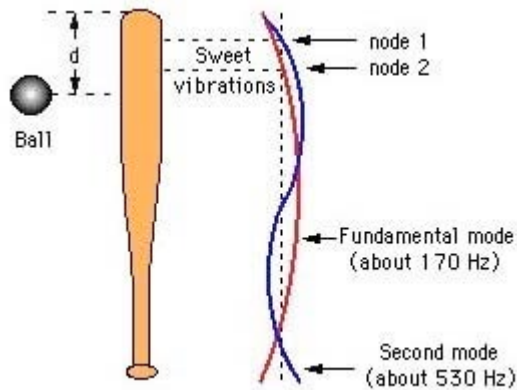

- **Factors affecting the restitution of bouncing ball**

The coefficient of restitution or COR of an object is a fractional value representing the ratio of velocities before and after an impact. But as it is difficult in the lab to measure velocities you can measure bounce heights and work out the velocities. Actually restitution is just the ratio of the square of the heights. You could investigate if restitution decreases as the number of bounces continues (or just change the starting height). As a matter of interest, the International Table Tennis Federation specifies that the ball must have a coefficient of restitution of 0.94. What is the effect of temperature, gas pressure, mass etc? If you are comparing balls (eg golf vs tennis vs cricket you would need to know why you are doing this and what you hope to show. The fact that they are different may be of little interest in terms of physics concepts.

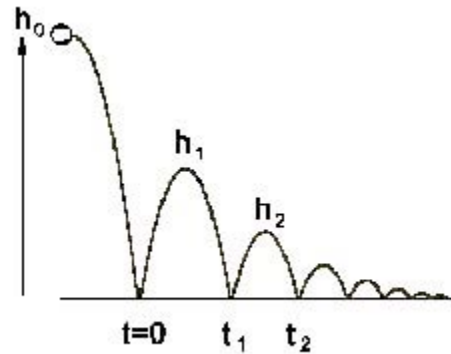
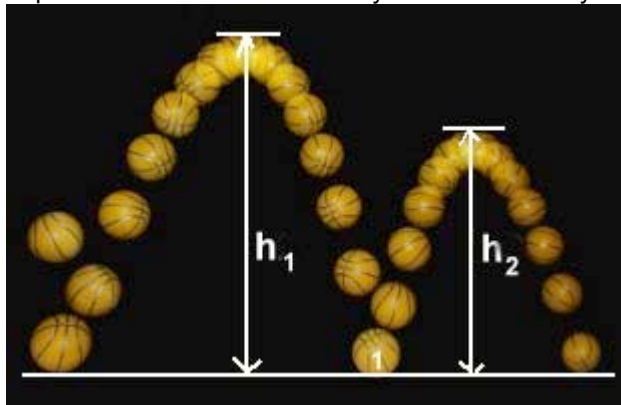

- **Friction and temperature**

Have you seen racing car drivers spin their wheels before a race to get the tyres hot and sticky and to increase friction (perhaps)? Just how does temperature affect friction? Are intermolecular attractions reduced as temperature increases? A neat little EEI would be to measure frictional force between two surfaces and then heat them up (in an oven) and measure it again. Have a look at the nosewheel of this Italian Air Force G222 transport plane at 2002 Riat airshow!



- **Newton's Law of Cooling**

In 1700 Newton published his *Law of Cooling* (in Latin) which stated that the rate of change of the temperature of an object is proportional to the difference between its own temperature and the ambient temperature (i.e. the temperature of its surroundings) when "placed in a wind blowing uniformly, and not in a quiet Air, that the Air heated by the Iron might always be carried away by the Wind, and the cool Air might succeed in its place". Most texts leave out the last sentence. I checked 17 university Physics texts at Griffith University and only one mentioned that the Law only applies in a breeze. Throughout the 1800s physicists also forgot about the breeze until a physicist at Edinburgh University (Prof. Crichton Mitchell) reviewed the original in 1887 and pointed it out to everyone. A good EEI would be to see if Newton's *Law of Cooling* applies with or without a breeze, and if the strength of the breeze makes a difference. An old

shotput with a drilled hole for a thermometer probe might be a good start.



- **Atwood machine and 'g'.**

The Atwood machine was invented in 1784 by Rev. George Atwood as a laboratory experiment to verify the mechanical laws of uniformly accelerated motion. Atwood's machine is often used to measure 'g'. But how accurate is it? Surely the friction in the pulleys would defeat accurate measurement. But perhaps friction is lower when the masses are lower and maybe accuracy improves. Perhaps it is more accurate when the difference in masses is great. Who knows. Why don't you find out?

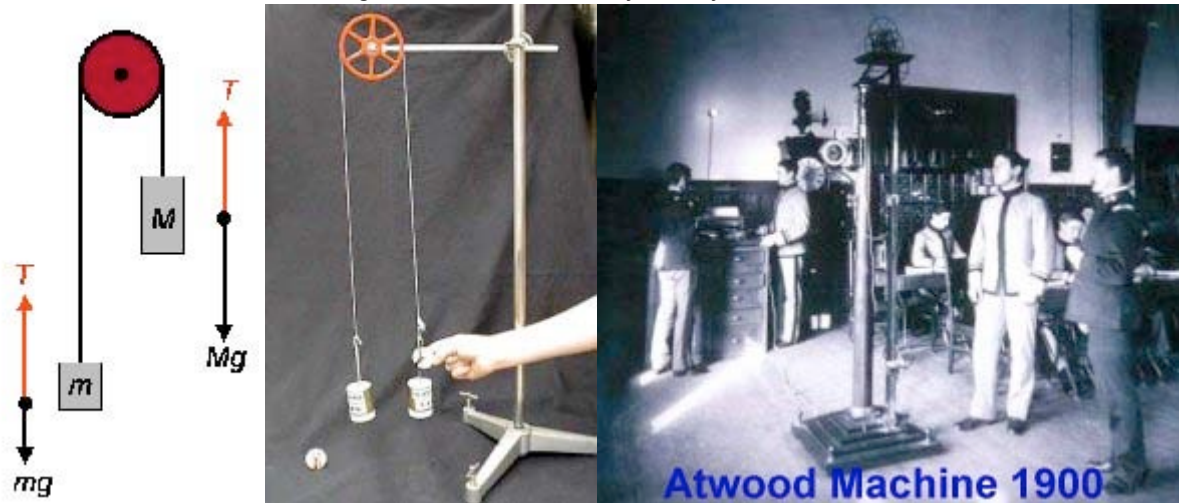

What is the 'best' way to heat water; kettle or microwave oven?

You'd think that a kettle would be as it is designed to heat water; but the microwave is more modern and could be better or more efficient. But what is efficiency? What does 'best' mean here? How is efficiency

affected by volume of water; time of heating. Should energy input be kept constant, or just time?

What's the best way to heat water?



A microwave oven....



....or a kettle?

- **A rubber band under stretch and relax**

Elasticity is an important factor in the design of building frames. For example, what is known as the "hybrid frame" design provides elasticity in response to dynamic loading caused by an earthquake, and the effects are like a flat rubber band held at both ends and stretched. The rubber band will stretch but not break, and then return to its former state. A hybrid frame building reacts much the same way, resisting the lateral forces of the temblor and reverting to a static state after the action stops. You could model the behaviour of this building material using a rubber band and look at a number of factors: how many times can it be stretched; effects of temp; coefficient of restitution vs cross-sectional area of rubber, and so on.

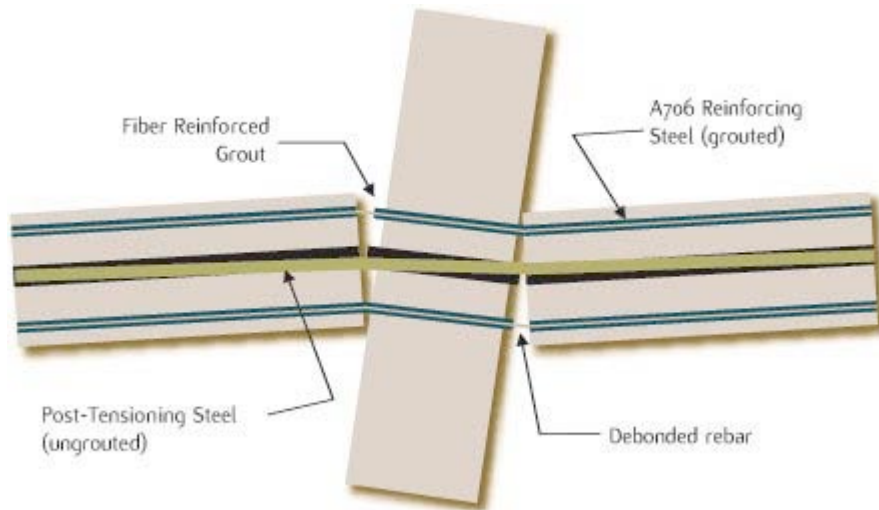

- **Meteorites and tsunamis**

When an asteroid hits the ocean at a typical speed of 70000 kmh^{-1} there is a gigantic explosion. The asteroid and water vaporize and leave a huge crater - typically 20 times the diameter of the asteroid (that is, a 100 m asteroid will create a 2 km diameter crater). The water rushes back in, overshoots to create a mountain of water at the middle and this spreads out as a massive wave - a tsunami. The centre of the crater oscillates up and down several times and a series of waves radiate out. You could investigate how the diameter of the crater relates to the diameter, speed, density, mass of the meteorite. I think a video camera might be necessary for this. If this is too awkward perhaps letting objects of different size, mass, speed etc fall into sand (fine, coarse) might be easier.

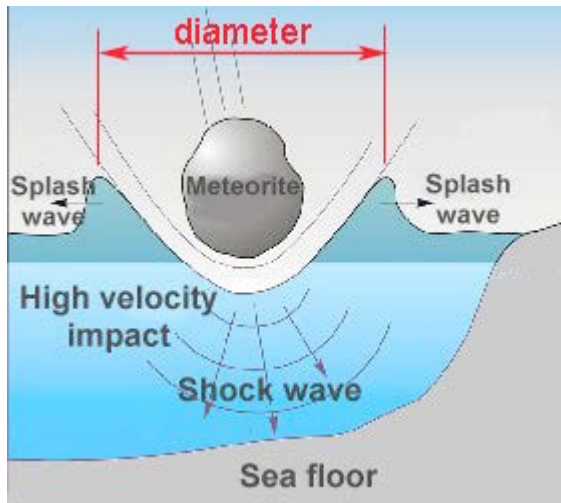

- **The angle of a meteor strike and crater shape**

Why are impact craters always round? Most incoming objects must strike at some angle from vertical, so why don't the majority of impact sites have elongated, teardrop shapes? If you throw a stone into sand on the beach at even a small angle from the vertical you get an elongated crater; so why not for real meteors? The answer seems to be that the physical shape and direction of approach of the meteorite is insignificant compared with the tremendous kinetic energy that it carries. Elliptical craters may only show up at really small angles for meteors. However, a good EEI would be to model impact angle using marbles in sand, or in flour. A layer of cocoa powder on top of the flour makes it easy to photograph.



- **Thermal conductivity**

Thermal conductivity, k , is the property of a material that indicates its ability to conduct heat. It is very

important in industry. One interesting way I've seen is to drop a cube of metal into water in a polystyrene cup and measure the rate of heating of the water. Seems so simple but is it accurate? Is surface area important? Doesn't the rate of warming slow down as the difference in temperature gets less? An interesting application of thermal conductivity testing is shown below. Here they are trying to get an accurate value of the existing soil conditions for a geothermal project.

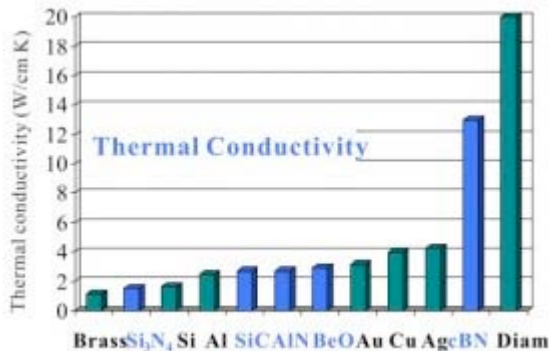

Investigate conservation of momentum and kinetic energy in two dimensions

A good EEI if you like billiard table physics. Measure the effect of 'English', spin, position struck etc; any access to TI /Casio/Pasco photogates? This is too much fun to be Physics.

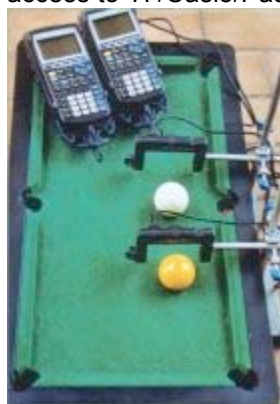

- **Analysis of projectile motion using a digital video camera.**

Get hold of a high definition video, and high speed with frame rates 300fps, 600fps and 1200fps (although 1200fps is small image and needs really good lighting). The Casio EXILIM Pro EX-F1 Digital Camera (<\$1,000) is supposed to be great according to teachers who have used it for motion capture. One teacher said that as the Casio Exilim EX-F1 is not available in Australia he imported it from Hong Kong via eBay. All up cost with a 16G memory card and extra battery was just under AU\$1000. His other comments can be viewed by clicking [Casio EXILIM](#). However, the problem with high definition videos is that they are compressed to the hard drive and this causes some issues with some data capture programs such as Logger Pro.

(Some ideas: football, springboard diver motion: s/v vs t ; what variables to change; must collect first hand

data).



Casio EXILIM Pro EX-F1

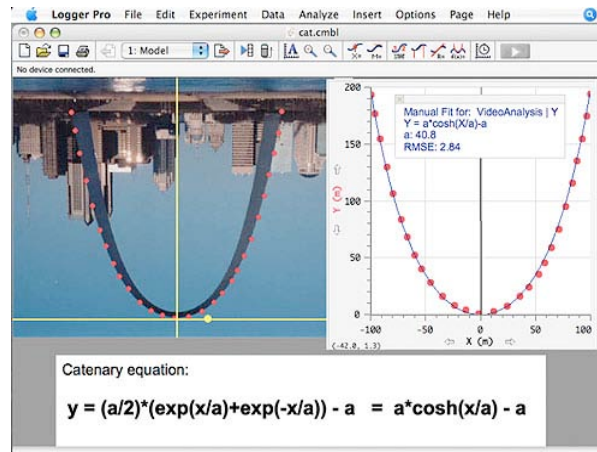

- **Interference effects of sound in a room**

Audio engineers go to a lot of trouble working out the best placement of loudspeakers in a room. For example the recommended placement for 7.1 Channel Surround Sound is: **Front speakers should be placed at the edges of the screen, toed in to face the central listening location, and the tweeters should be ear height. The center speaker should be placed behind the screen (when using projection) or over or under a TV, and as close to ear height as possible. Side channel speakers should be placed on side walls, to the left and right of the listening position, equidistant from the front speakers and the rear speakers. Rear channel speakers should be placed on side walls, slightly behind the listening position, and should have a normal high-quality monopolar construction. Front speakers should be at ear height and surrounds should be above ear height. See diagram below.** It is even hard enough just getting the placement right for a simple two-channel stereo. A part of the problem is because even a pair of sound sources (speakers) emitting a monophonic sound generate interference in the room - even without considering reflections off the back and side walls. An interesting EEI would be to try one and then two speakers in a room (say left and right front) emitting a pure tone from a frequency generator and measure and account for the nodes and antinodes (as measured with a microphone and CRO). You can decide the controls and manipulated variables (but keep it simple).

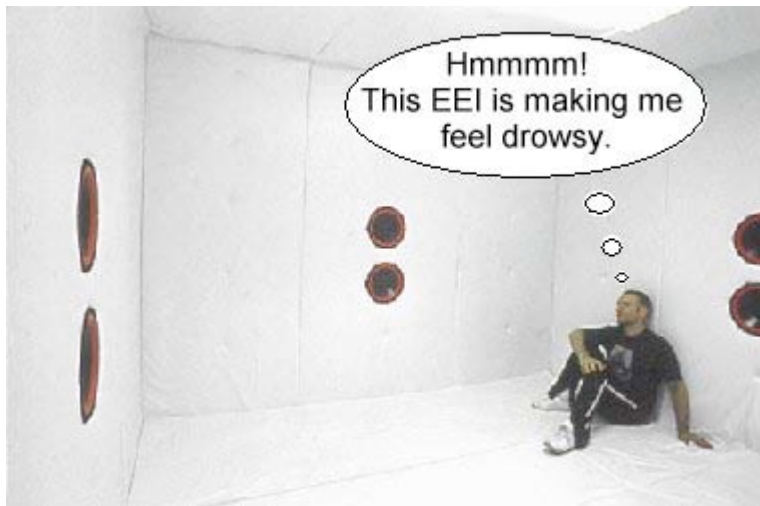
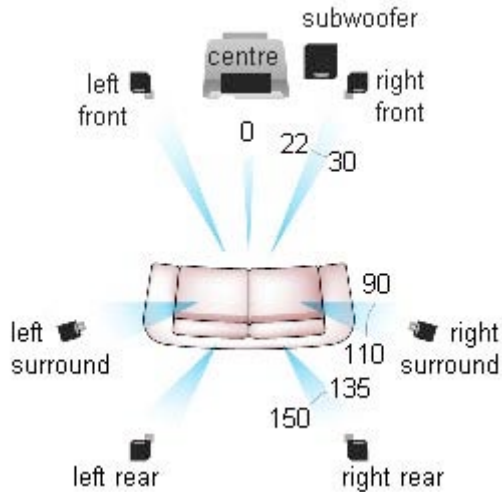

- **Specific heat of metals**

It is pretty useless just measuring the specific heat using a calorimeter and water; that's hardly an EEI deserving of an "A" standard. But if you can optimise the method and improve its accuracy then you could be on to a winner. How do volume of water, initial water temp, mass of metal, size of calorimeter (copper vs polystyrene foam and amount of insulation affect the accuracy? Are you going to do it electrically? If so, won't the resistor heat up and change resistance as the experiment progresses; are you using a stable DC source or a unfiltered rectified AC source from a lab power supply that is bumpy (see diagram below)? This may affect your voltmeter reading and the calculation of energy transferred:



- **Investigate the resistivity of different types of graphite**

Carbon composition resistors are made from a molded carbon powder that has been mixed with a phenolic binder to create a uniform resistive body. It is then surrounded in a insulating case after attaching end leads. The greater the % carbon the lower the resistance. You could model a resistor using graphite 'lead' pencils. It is the pencil-makers' policy not to reveal the %carbon in their pencils but I have it on good authority that 9B is 25% clay and 75% graphite and this changes in equal steps to 9H which is 75% clay and 25% graphite. For an EEI you could measure V vs I for 4B through to 4H pencil graphites; what's the difference (% clay?). How does diameter affect result?

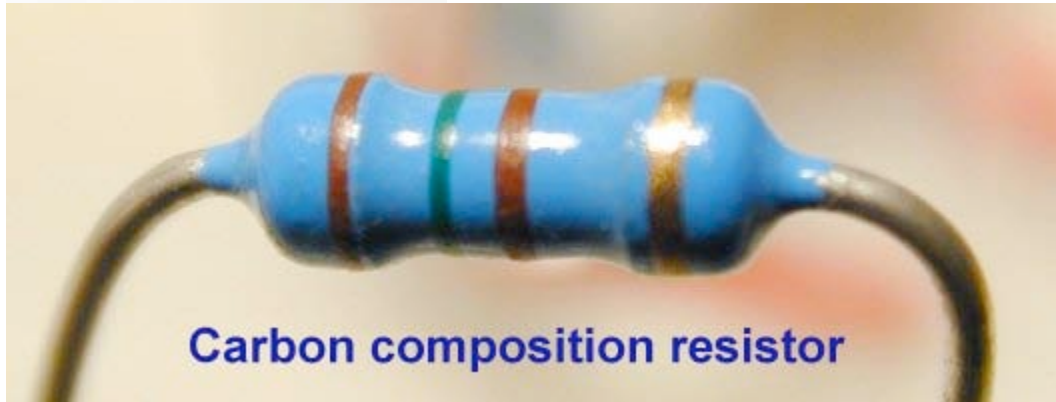

- **How high will water syphon?**

Use clear plastic tube 20 m long in U-shape; effect of boiling water first; effect of temperature. Is the density of the liquid the main factor or is vapour pressure or intermolecular force a factor?



- **Investigate the coefficient of friction for accelerating surfaces**

For sliding friction on an incline, the coefficient of friction $\mu = \tan \theta$ for constant speed; but if the block is accelerating life is not so simple. You could investigate friction for objects being shot up an incline and coming to rest (what to vary, what to control?). What about the motion of a block of wood resting on top of

a piece of wood that is oscillating back and forth?

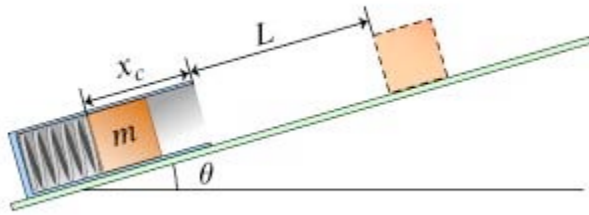

Shoot up incline

Egg cooking

The yolk and white of an egg have different thermal conductivities so I'm told. So how does the temperature rise of the two parts of an egg compare when it is being boiled. Much work has been done on eggs but maybe not on this. I'd say you'd need the temperature probes and a lab interface of some sort.

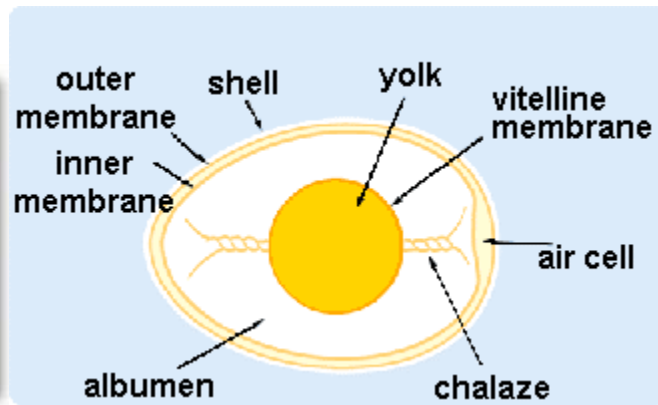
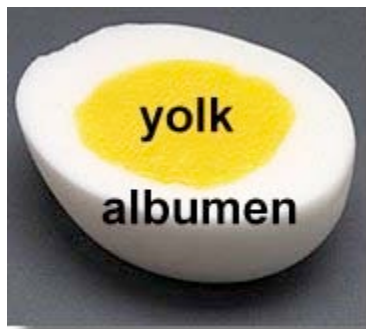

- **Investigate the ballistic pendulum**

(does accuracy in measurement of speed vary with speed of projectile; what is the optimum mass of the pendulum bob (plasticine) and string length for different speeds or momenta?)

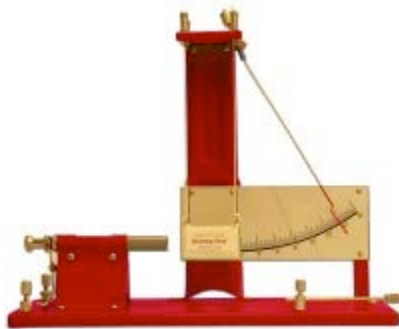
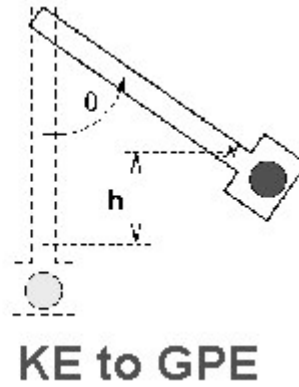
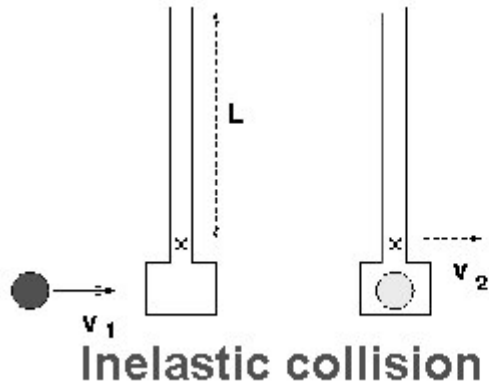

- **Investigate the absorption of sound at different frequencies**

In the music rooms at Moreton Bay College there are large sliding panels hanging from the wall. One side of the panel is covered with a loop-pile carpet, the other side has cork. I asked the architect why he did this and he said so they could 'tune' the room and remove annoying frequencies. You could do an EEI to investigate the sound deadening effect of different substances. How does % absorption vs thickness; vs frequency; vs loudness. What relationship is there with density of the sound absorbing barrier?)



Sound curtain

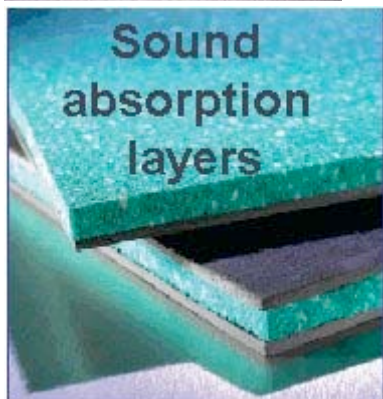

Acoustic foam

- **Meniscus shape**

Think of how many times your teacher has cautioned you to "read to the bottom of the meniscus" when you're using a measuring cylinder, pipette or burette. A characteristic of liquids in glass containers is that they curve at the edges. This curvature is called the meniscus. Think of how many times your science teacher warned you to read to the bottom of the meniscus when reading measuring cylinders and so on. How does the meniscus angle change with temperature, type of liquid (eg various alkanes), density.

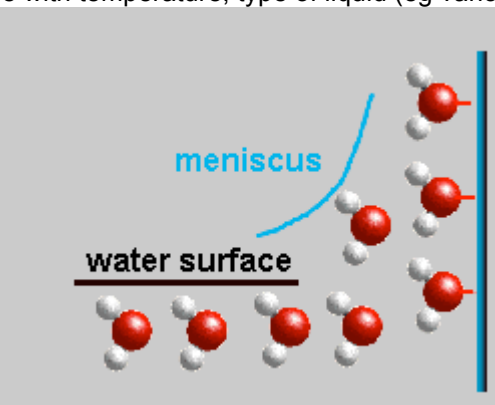
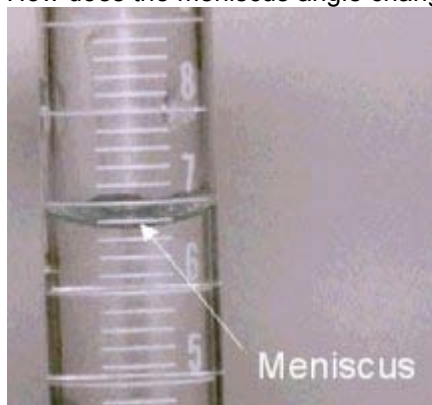

- **Construct and investigate a simple, tuned musical instrument**

Which harmonics are emphasised (odd/even); factors affecting the sound envelope (attack, sustain, decay); how can you modify your instrument to increase the range of frequencies both higher and lower?

As a start, I've measured a school xylophone but removed some of the key dimensions.

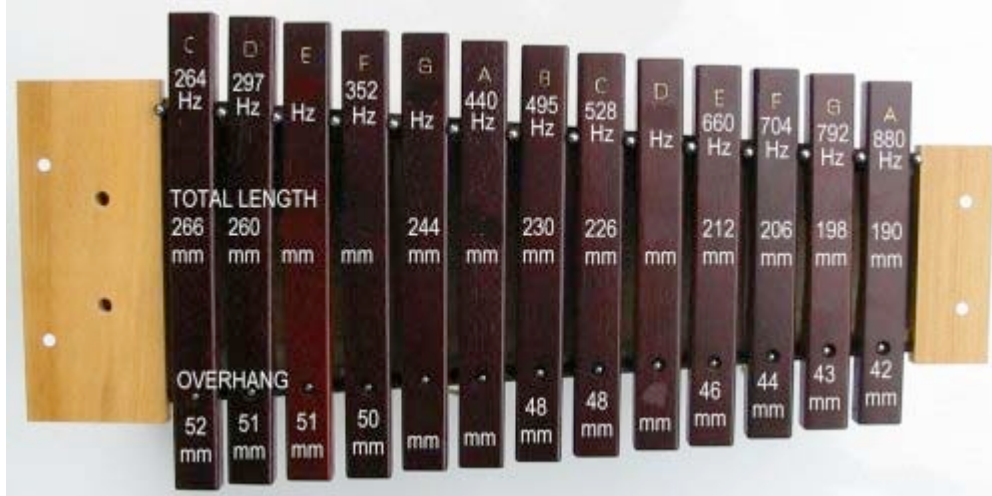

- **Investigate the speed of sound in air**

It is said that the speed of sound increases by 0.6 ms^{-1} for every degree Celsius rise in temperature. But is this accurate over a wide range of temperature change? You could investigate: speed vs temp; vs humidity; speed in different gases (different densities, molar masses). Or how does it vary from a day of high pressure (eg 1020hPa) to a low pressure day (eg 995hPa)?

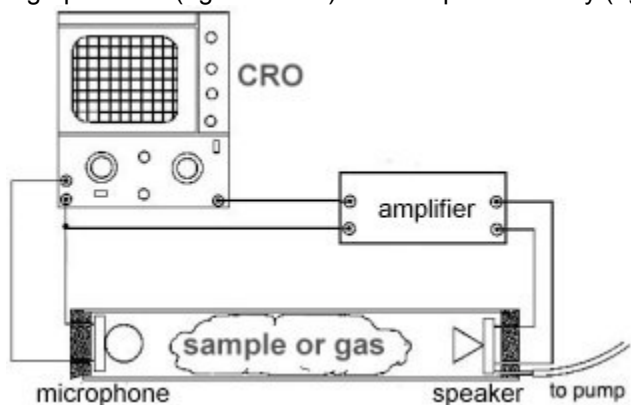

- **Self-inductance in a solenoid**

Consider the circuit below (left). Nothing happens to the brightness of the bulb when the metal rod is inserted into the coil. But if you use the circuit on the right where the source of power is an alternating current, insertion of the rod affects the brightness. This illustrates the property of self inductance. As a consequence of this, when a DC supply that is connected to a solenoid and is switched on, the current doesn't respond immediately. The same is true when the circuit is switched off. You could investigate the effect of different metal bars, coil size, size of AC etc. A CRO may be better than a bulb for getting quantitative data.

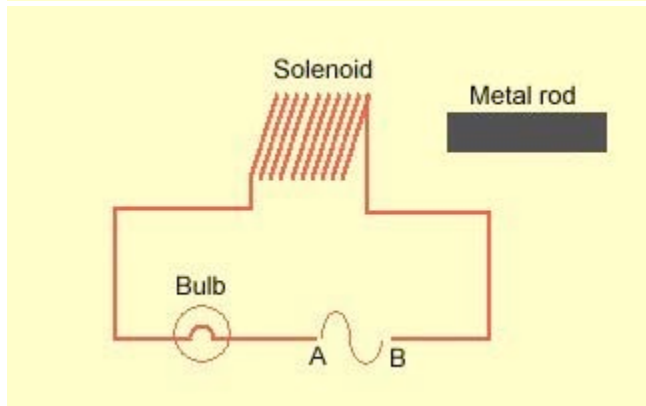
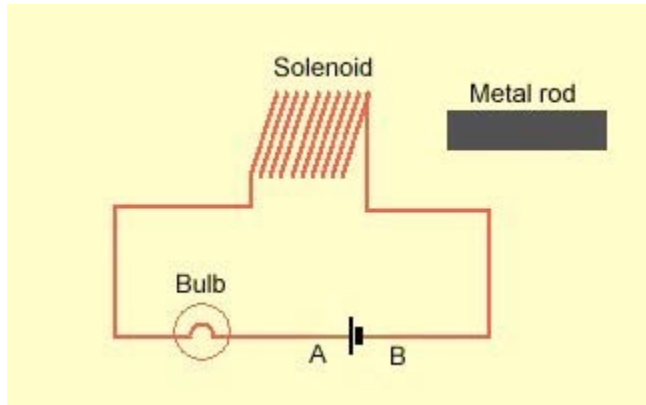

- **Molecular sizes of gases**

You know how helium balloons deflate rather quickly as the gas leaks through the porous rubber? Well, a hydrogen balloon deflates even quicker as it's molecules are even smaller. You would think that the rate of deflation would somehow vary with the molecular size.



- **Investigate the factors affecting the resistance of a resistor**

You could measure resistance vs temperature; linearity with increasing voltage. Solder wires on to each end, wrap it in *GladWrap* and put in a test tube (with a thermometer) and place in a beaker of water to be heated. Try different resistances. Can you get some dry-ice; how about getting some liquid nitrogen

(under supervision)?



Measure the audible range of a human being

You could measure frequency range, loudness; may be able to get access to audiologist's equipment; variation with age, sex, occupation; test family and friends. But how do you stop it being so subjective. Where does the physics come in?

- **Wing lift**

One of the things keeping a plane in the air is lift. Lift is produced by a lower pressure created on the upper surface of an airplane's wing compared to the pressure on the wing's lower surface, causing the wing to be "lifted" upward. The special shape of the airplane wing (airfoil) is designed so that air flowing over it will have to travel a greater distance faster, resulting in a lower pressure area (see illustration) thus lifting the wing upward. Lift is that force which opposes the force of gravity (or weight). You could make models of wings and place them in front of a fan. Vary the attack angle, shape and so on. Clue: read up on The Coanda Effect.

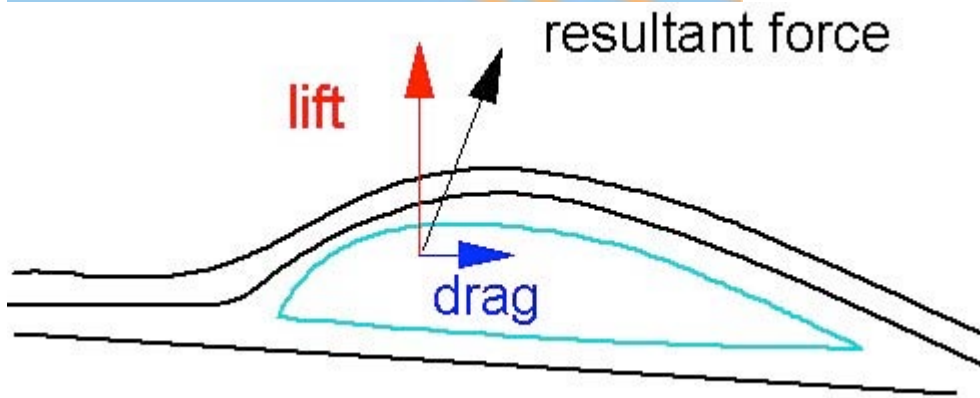
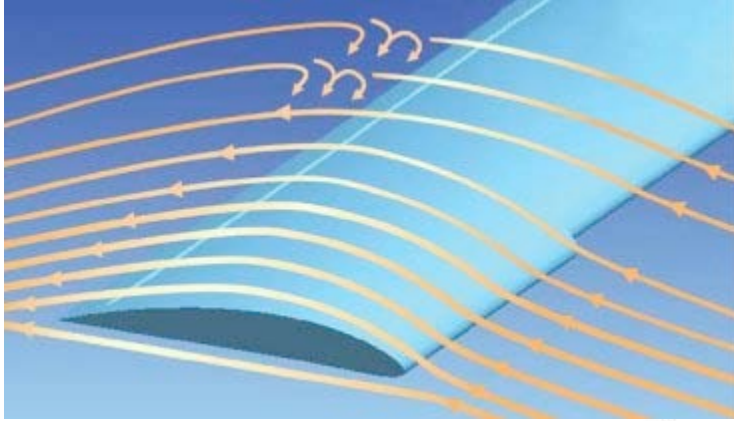

- **Investigate the interference of sound waves**

Can a wave be superimposed on another to cancel out the sound? This is what they do in noise-cancelling headphones and car interiors. Maybe too complicated for an EEI but you could look at interference of waves between two speakers and measure the degree of cancellation (but how to minimize reflections off the walls?).

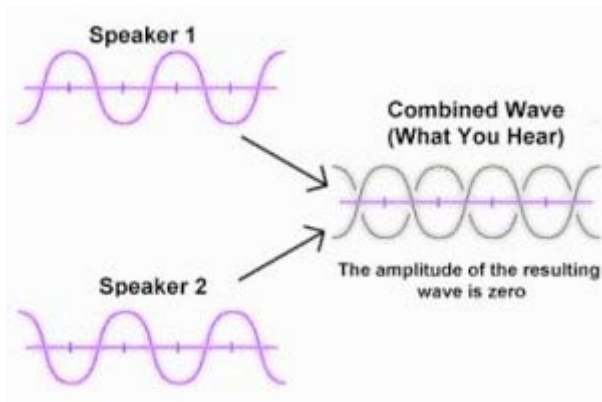

Noise cancelling headphones

- **Rate of cooling and surface area**

An interesting EEI can be made from filling balloons of different sizes and shapes (cylindrical, spherical) with hot water and measuring cooling rates in a gentle forced breeze. You can look at shape and surface area.



- **Transformers and power losses**

Electrical transformers are used to "transform" voltage from one level to another, usually from a higher voltage to a lower voltage. A changing current in the first circuit (the primary) creates a changing magnetic field; in turn, this magnetic field induces a changing voltage in the second circuit (the secondary). Transformers are some of the most efficient electrical 'machines', with some large units able to transfer 99.75% of their input power to their output. Your EEI could be about the factors that influence the power losses. Is it frequency, voltage, current or just what? What ever you do, don't use mains (240V)

voltage. Use the school's laboratory power pack or a signal generator.



- **Perpetual motion machines.**

Now we know they can't work but trying to figure out why they can't work is a bit harder. You could make a few models from designs on the internet and work out what they don't work. You'll need some estimate of % efficiency and that might be hard to gather.



- **Variables that affect drag forces in boats.**

The "Hull Speed" is the maximum speed before drag increases dramatically. For a 30m ship it is about 24km/h; for a 30cm duck it is about 2.4 km/h. There's lots to test and talk about there. I'm guessing it's all to do with the ratio of surface tension to hull area. Variables: drag vs speed; length; width; shape.

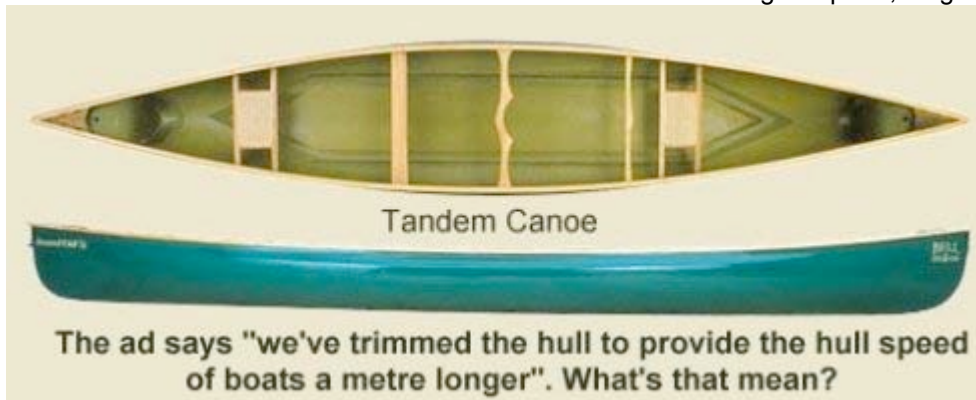

- **Switching from walking to running**

Prof. McNeill Alexander from Leeds University (UK) developed *Alexander's Rule* which says that $v^2 = gd_H/2$ (where d_H is the distance from hip to ground) that shows the speed at which an animal switches

from walking to running and this is supposed to work for insects to humans. But I'm not so sure! How could you do an EEI on this? Better get good advice from your teacher before you start.



- **Controlling the speed and direction of sailboats**

Hint: collision trolley, sail, electric fan, spring balance; wind force vs angle, speed of wind, area of sail; say no more!

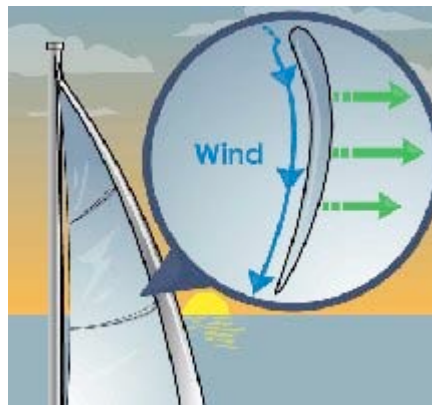

Does pyramid power really work?

What possible forces; size of pyramid, material, angles, what to test (freshness of eggs?); is this really science?



- **DC Motor**

What factors affect the rotational speed of a simple DC motor. You'd think that as you increased the voltage it would just get faster and faster, but alas, a thing called "back EMF" spoils the party. What factors are involved here?



Why not dissect one first?



Simple motor



Home made motor from *Churchie*.

Click image to enlarge.

- To determine if Mersenne's law of stretched springs applies to slinkies.

Well why shouldn't it; it is the same principle. But how do you minimize friction. And what about the heavy spring: snaky?



Slinky



Snaky

- **To investigate the factors which affect the specific heat capacity of various concentrations of salt water solutions.**

In a lot of questions you are told to take the specific heat of a solution (seawater, milk) as being the same as distilled water. But is this fair? Maybe some of the heat is used to increase the vibration of the hydrated Na^+ and Cl^- ions. But wait - 100 g of salt water has a smaller volume than 100g distilled water so maybe.....

NaCl crystal NaCl in water

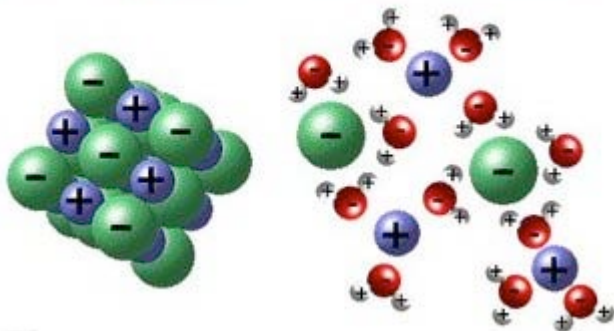

- **To measure the specific latent heat of vaporisation of liquid nitrogen.**

The specific latent heat of vaporisation of water is not such a big deal - it has been done to death by physics students in laboratories all over the world for the past 140 years. But this is an EEI and critical thinking has to be applied. That's why nitrogen could be tried. Liquid nitrogen is not easy to get hold of or store, and even less easy to handle. Doctor's surgeries often have it to freeze off warts and skin cancers so maybe there's a clue. It wouldn't be easy but with teacher guidance this could be a great EEI.

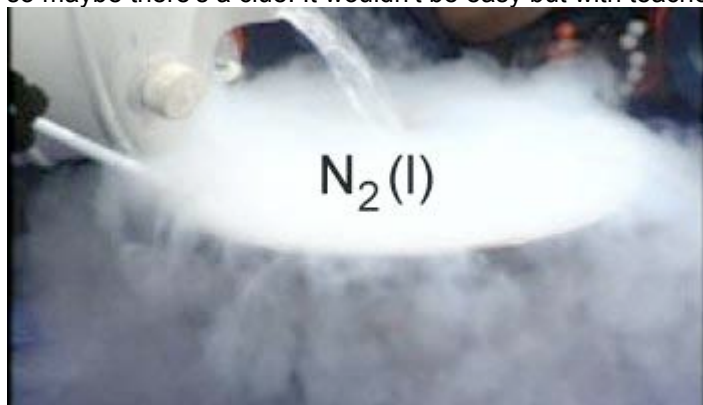

- **To determine the effect of changing temperature on the viscosity of honey.**

Have you ever tried to eat honey that has been in the refrigerator - hopeless huh? Both the viscosity and the density of honey change with temperature and water content and I'm told the viscosity and temperature follow an inverse cube relationship. Honey is mostly sugar (glucose/fructose and water). Thus the two variables seem to be temperature and moisture content. But how will you control moisture, and how will you measure viscosity (maybe a ball bearing - but what size and what about the diameter of the

tube - is there viscous drag)?



- **Can a pendulum predict the sex of a chicken while it is in the egg?**

Is this really physics?; what forces are acting?; who thought of this? You'd have to be very confident or plain daring to choose this for an EEI.

- **Can eggs stand more force from some directions?**

Build a pressure gauge; can it be connected to a TI-CBL or computer; what is the hypothesis?. Does cooking (for how long) affect this?

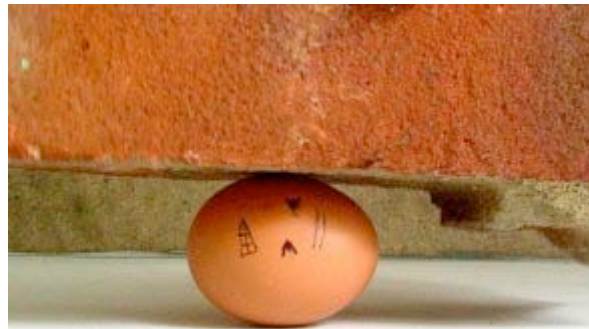

Eggshell pressure test



- **How strong is human hair of different thickness?**

For a healthy individual with no hair diseases, hair fibre is very strong with tensile strength around $1.6 \times 10^{-9} \text{ N m}^{-2}$. That makes hair about as strong as copper wire of the same diameter. So as you can see hair is incredibly strong. It also has elastic properties. It can stretch up to 20% of its original length before breaking when it is dry and when it is wet it may stretch up to 50% before breaking. But do you believe

the ads that say their products can improve the strength of hair (see the one below). Sounds a bit far-fetched to me. You could measure elongation vs weight; breaking strength vs diameter; vs colour; are different colours more stretchy (how to control variables?); effect of humidity, heat, prolonged light, age of subject and so on.



- **How strong are nylon fishing lines?**

Platypus is Australia's leading and oldest brand of fishing line. One of their ads said: ***"Platypus Super-100™ has been crafted using a new process, allowing an outer skin to be toughened while the core remains supple and flexible. An advanced coating is also applied to the line for added abrasion resistance. Platypus Super-100™ is fast gaining a reputation as the only choice for serious anglers, both as mainline and as tippet. Platypus has spent many years perfecting the resin blend and fine tuning their production methods to bring Super-100™ to you"***. Does this sound like a lot of advertising hype? Perhaps you could try different brands and measure strength vs diameter; or another variable. What is the hypothesis going to be?



- **Which truss design supports the most weight?**

You've probably noticed how bridges seem to be made up of lots of triangles (or 'trusses'). In architecture and structural engineering, a truss is a structure comprising one or more triangular units constructed with straight slender beams whose ends are connected at joints referred to as nodes. External forces and

reactions to those forces are considered to act only at the nodes and result in forces in the beams which are either tensile or compressive forces. You could investigate how a paddlepop stick truss reacts to a load added to the top. You could reduce the thickness of a beam and see if it affects the load capacity before it breaks. Physics teacher Stuart Halsey from St Edmund's College, Ipswich, uses and recommends the "Truss Force Analysis" Sim available on the Johns Hopkins University website at <http://www.jhu.edu/~virtlab/bridge/bridge.htm>. He says that it is useful for students to learn the ins and outs of bridge design, building, testing and (ultimately) destruction. Stuart also uses it for investigations on the school's "Days of Excellence".

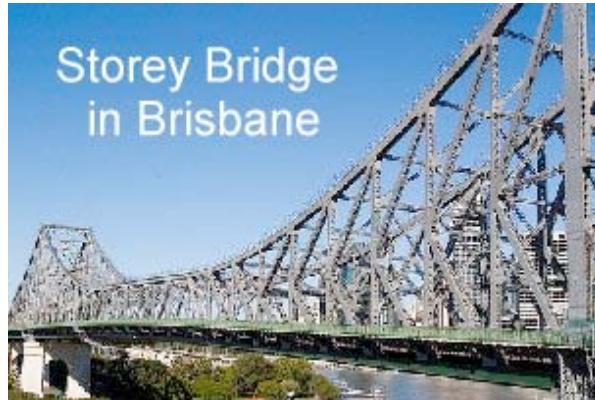
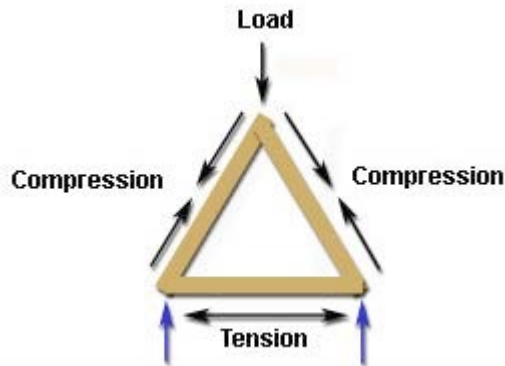

Which beam design makes the strongest truss?

As a continuation of the above suggestion, you could combine a couple of trusses and see how they then react to the loads. After all, in the middle node at the bottom, tension now becomes compression.

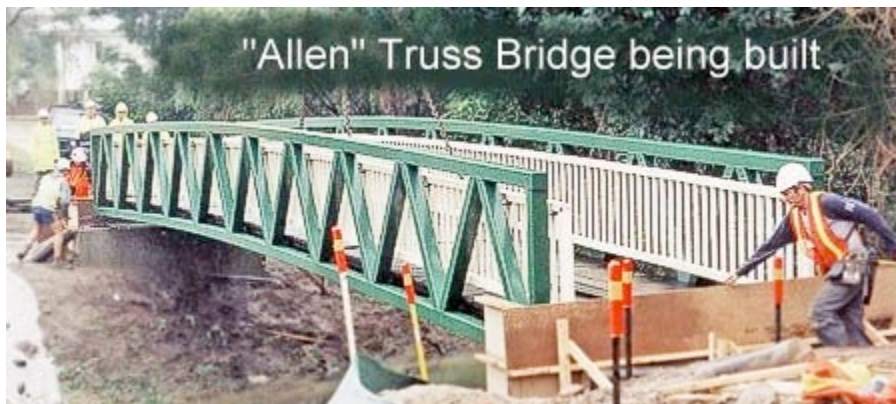
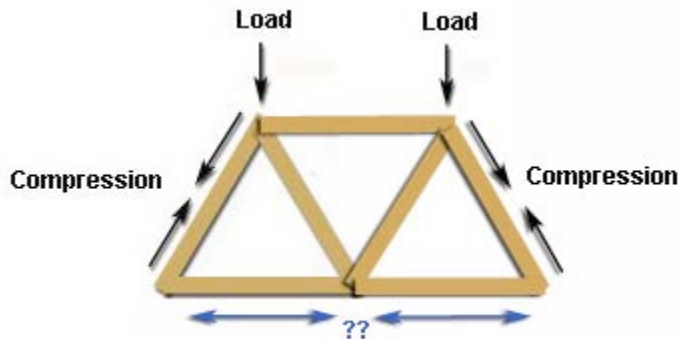

- **How strong is silkworm silk?**

Silk is a continuous filament fibre consisting of fibroin protein secreted from glands in the head of each silkworm larva and a gum which cements the two filaments together. To make useful thread for clothing, the raw silk is twisted into a strand sufficiently strong for weaving or knitting. Four different types of silk thread may be produced from this procedure: crepe, tram, thrown singles and organzine. **Crepe** is made by twisting individual threads of raw silk, doubling two or more of these together, and then twisting them again. **Tram** is made by twisting two or more threads in only one direction. **Thrown singles** are individual threads that are twisted in only one direction. **Organzine** is a thread made by giving the raw silk a preliminary twist in one direction and then twisting two of these threads together in the opposite direction. How does the strength of the four methods compare? What's the hypothesis? You can get cocoons from ebay for \$12 including postage for 33 cocoons. Posted from the Sunshine Coast, Queensland.

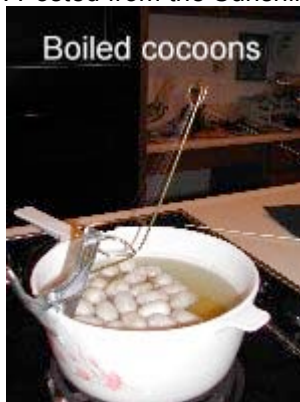

- **The effect of light on degradable materials**

Biodegradable plastics are seen by many as a promising solution to the problem of single-use conventional plastic bags. Although there are a variety of degradable plastics which may assist reducing the resource wastage and litter problems associated with plastic shopping bags, there is unfortunately no easy solution. Degradability is the ability of materials to break down, by bacterial (biodegradable), thermal (oxidative) or ultraviolet (photodegradable) action. If you can get hold of a degradable plastic bag you could test the thermal and photodegradable properties by measure the breaking strain before and after treatment. Is the wavelength important, or is it just the intensity? Is temperature important, or just time? A great EEI and so useful too. A source of biodegradable plastic are the wrappers some magazine come in (ask at the library or your teacher): these include *Chemistry in Australia*, *Australian Physics* and *New Scientist* (see photos below).

- **Polarisation of light in acidified sugar solution**

Certain materials (sugar in this experiment) are optically active because the molecules themselves have a twist in them. When linearly polarized light passes through an optically active material, its direction of polarization is rotated. The angle of rotation depends on the thickness of the material and the wavelength of the light. You could make up a solution of sugar (sucrose) and hydrolyse it using dilute acid. As the reaction proceeds, the degree of polarisation changes and this can be observed using crossed polarisers either side of the solution placed on an OHP. You could look at the effect of angle vs. concentration vs time; depth effects; acidity effects; temperature.



- **Comparing the strength of laminated and unlaminated wood beams**

Make your own plywood out of paddlepop sticks. How does breaking force or deflection vary with number

of sticks? Turn the beam on it's side and try again.

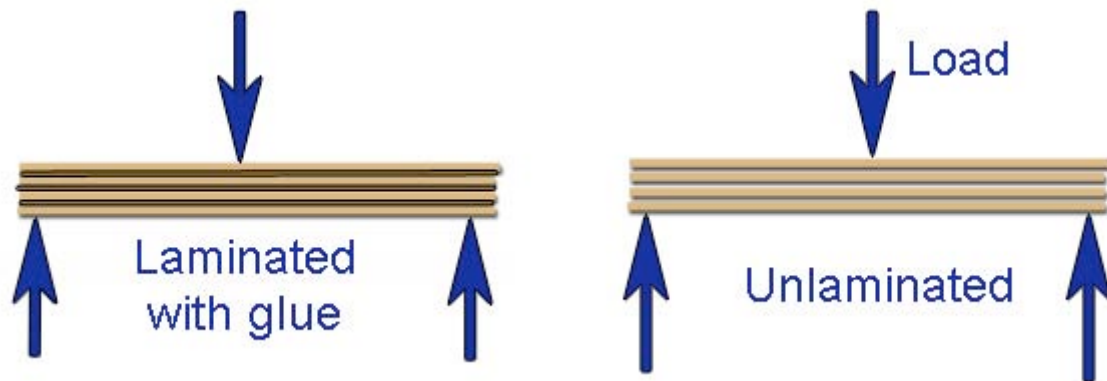

- **How do different woods expand when they are wet?**

In which direction do they swell (if at all)? Is it a linear function with % moisture? If they swell, do they become more or less dense? What physics principles are being tested?

HERE ARE SOME WITHOUT HINTS

- High static, low static and anti-static carpets
- Why does cling wrapping cling?
- The pitch of xylophone bars of different materials
- What is the range limit for a string telephone?
- The harmonics in a note, using Helmholtz resonators
- Humidity and the speed of sound in air
- The speed of sound in salt and fresh water
- An efficient thermopile
- Jacob's ladder
- The Tesla coil
- Vibration in a wire carrying AC electricity
- Negative resistance phenomena
- Practical uses of the Hall effect
- Eddy current heating
- Paramagnetism

- Rainbows
- Schlieren photography
- Moiré fringes as measuring devices
- Triboluminescence
- Phosphenes
- Holography
- Producing a hologram
- Thin-film interference
- Kaleidoscopes
- Anamorphic art
- Tyndall figures
- Tyndall scattering and the sunset
- The Geissler tube
- A Wilson cloud chamber
- Celt stones
- Skipping stones
- The Marangoni effect
- Leidenfrost phenomena
- Lichtenberg figures
- Fraunhofer patterns
- The effect of cooling fins
- Maxwell's spot
- Kanizsa figures
- The McCollough effect
- The Pockels effect: or Pockels electro-optic effect, produces double refraction in certain crystals when a constant or varying electric field is applied.

- Applications of the pantograph
-

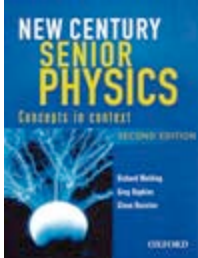

[Go to New Century Senior Physics - Second Edition Home Page](#)

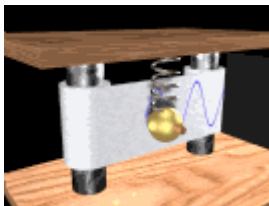

[Return to Senior Physics Resources Home Page](#)